

Source Four® **PARNeI**®

---

## Assembly Guide

Production Dates: September 2004 - Present

**ATTENTION:** The part numbers listed in this guide may differ from the parts required for your particular Source Four fixture. Part numbers for fixtures change occasionally as parts are replaced or upgraded.

To ensure that you are ordering the proper part for your specific fixture, please contact your ETC dealer, or ETC Customer Service for assistance.

# Table of Contents

---

Basic Assembly .....	1
Lamp Socket Assembly .....	2
Assemble lamp socket.....	3
Housing Assembly .....	4
Assemble housing .....	5
Cleaning the reflector.....	6
Cleaning the lens.....	6

ETC<sup>®</sup>, Emphasis<sup>®</sup>, Expression<sup>®</sup>, Insight<sup>™</sup>, Imagine<sup>™</sup>, Focus<sup>™</sup>, Express<sup>™</sup>, Unison<sup>®</sup>, Obsession<sup>®</sup> II, ETCNet2<sup>™</sup>, EDMX<sup>™</sup>, Source Four<sup>®</sup>, Revolution<sup>®</sup>, Sensor<sup>®</sup>, and WYSILink<sup>™</sup> are either registered trademarks or trademarks of Electronic Theatre Controls, Inc. in the United States and other countries.

All other trademarks, both marked and not marked, are the property of their respective owners.

ETC intends this document, whether printed or electronic, to be provided in its entirety.

# Basic Assembly

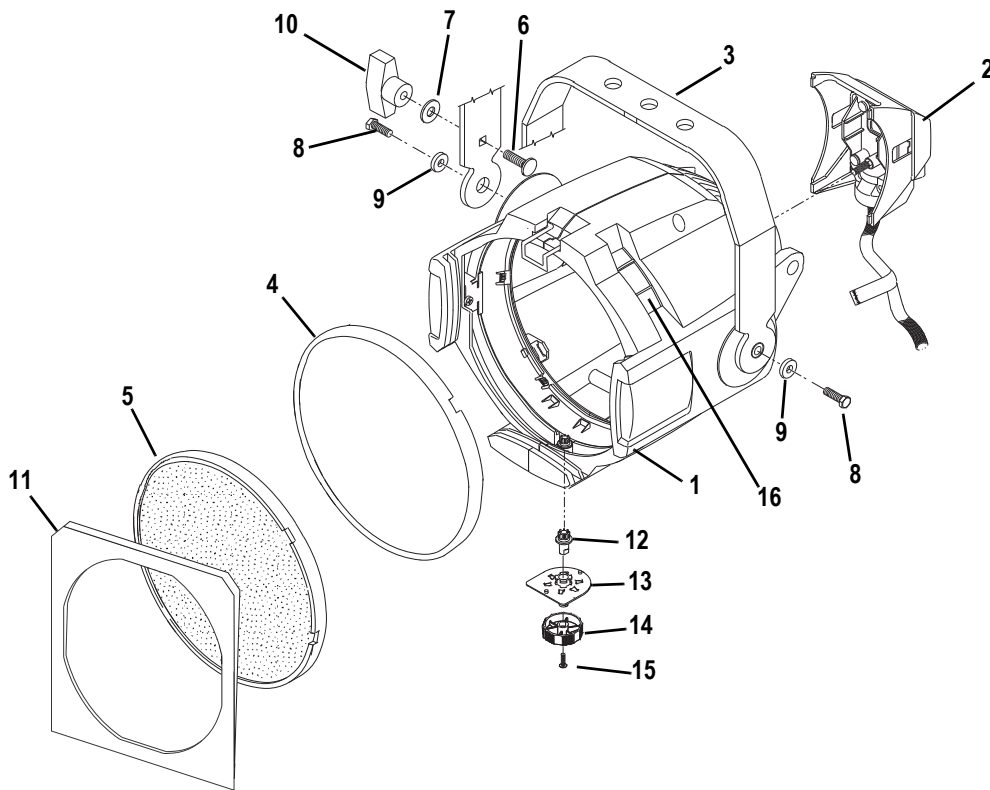

Figure 1

Reference Number	Part Number	Description	Quantity Required
1	7061A2020	Zoom base assembly, black	1
	7061A2020-1	Zoom base assembly, white	1
2	7061A2001	Lamp socket assembly, black (see <a href="#">Figure 2</a> )	1
	7061A2001-1	Lamp socket assembly, white (see <a href="#">Figure 2</a> )	1
3	7061A3006	Yoke bracket, black	1
	7061A3006-1	Yoke bracket, white	1
4	7061A4010-2	Zoom lens, clear/wave	1
5	7061A4010-1	Zoom lens, stippled/wave	1
6	HW5125	Bolt, carriage, 5/16-18 x.75, BO	1
7	HW5126	Washer, flat, .375 x.875 x.078, B/Z	1
8	HW5172	Bolt, Hex, 1/4-20 x 1, grade 5, B/Z	2
9	HW522	Washer, flat, 1/4, BZ	2
10	HW8144	Handle, yoke knob, black	1
	HW8144-4	Handle, yoke knob, white	1
11	7061A3007	PAR gel frame, 7.25"	1
12	7061A4014	Gear, focus knob	1
13	7061A4013	Bushing, focus knob	1
14	7061A4015	Focus knob	1
15	HW2154	Screw, PPH, 6-19 x 1.2L, 48-2, Plastic	1
16	7061A4012	Lens Rotator, black	1
	7061A4012-1	Lens Rotator, white	1

# Lamp Socket Assembly

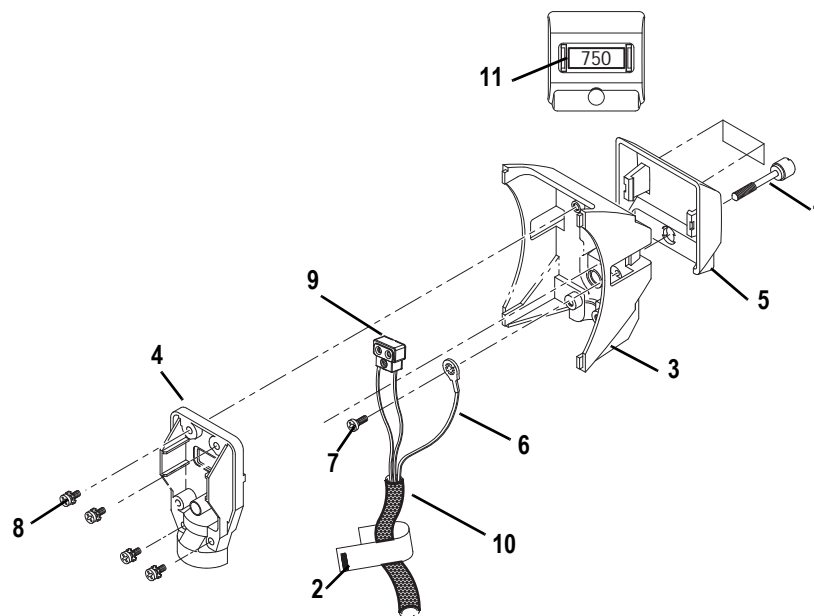

Figure 2

Reference Number	Part Number	Description	Quantity Required
1	7060A3025	Screw, 1/4-20 x 1.55, knurled	1
2	7060A4019	Label, Fixture Warning	1
3	7061A3023	Burner, casting, black	1
	7061A3023-1	Burner, casting, white	1
4	7061A3024	Strain relief, black	1
	7061A3024-1	Strain relief, white	1
5	7061A4011	Focus handle, black	1
	7061A4011-1	Focus handle, white	1
6	7061B7002	Ground Wire, 48"	1
7	HW2182	Screw, 6-32 x 1/4, PhPh, Taptite, zinc	1
8	HW3105	Screw, 8-32 x 1/2, PhPh, Taptite, SEMS	4
9	M706	Complete TP 22 CLCM assembly	1
10	W6195	Sleeve, fiberglass, 39", black	1
	W689-1	Sleeve, fiberglass, 39", white	1
11	7060A4094	Label, 750W, handle, black	1
	7060A4095	Label, 750W, handle, white	1

## Assemble lamp socket

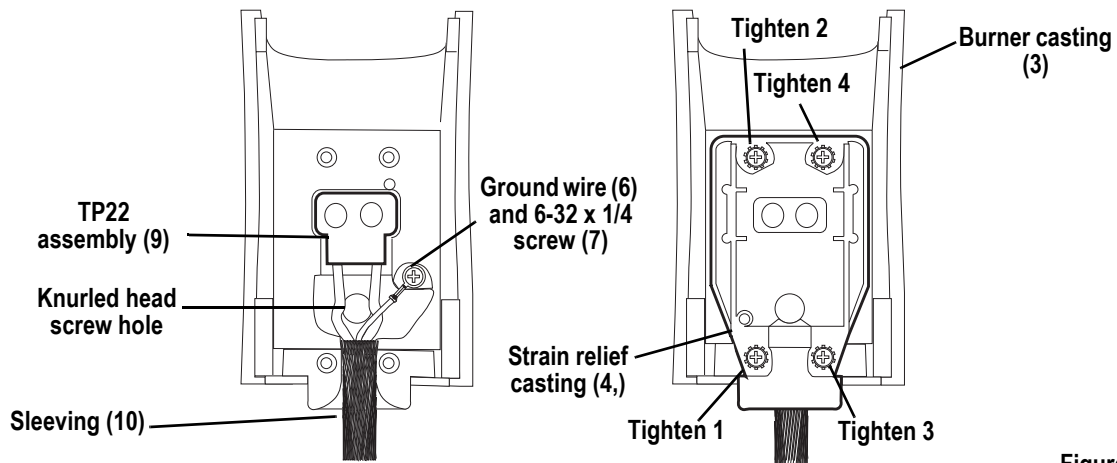

Figure 3

### Tools Required:

- #2 Phillips screwdriver

Step 1: Install the ground wire (6) and the TP22 assembly (9) in the sleeving (10). See [Figure 3](#).

Step 2: Snap the focus handle (5) onto the burner (3). See [Figure 2](#).

Step 3: Secure the ground wire lug (6) onto the burner casting (3) using screw (7).

Step 4: Place the TP22 assembly (9) into the burner casting (3). See [Figure 3](#).



**Note:** *Position the wires with the green ground wire on top of the two TP22 white leads. Make sure the green ground wire is not touching any part of the burner casting.*

Step 5: Insert the screws (8) into the four positions in the strain relief casting (4). See [Figure 3](#).

Step 6: Position the sleeving assembly (10) as shown in Figure 3. Fold the sleeving so it fits cleanly in the slot between the burner and the strain relief.

Step 7: Place the strain relief (4) on the burner casting (3). Loosely attach the screws (8). The TP22 assembly (9) must be centered in the strain relief opening (4). See [Figure 3](#).

Step 8: To guard against stripping the screws, tighten them in the order shown in [Figure 3](#).

Step 9: Make sure the focus handle is secure, then insert the knurled head screw (1) through the handle (5) into the burner casting (3). Tighten securely.

# Housing Assembly

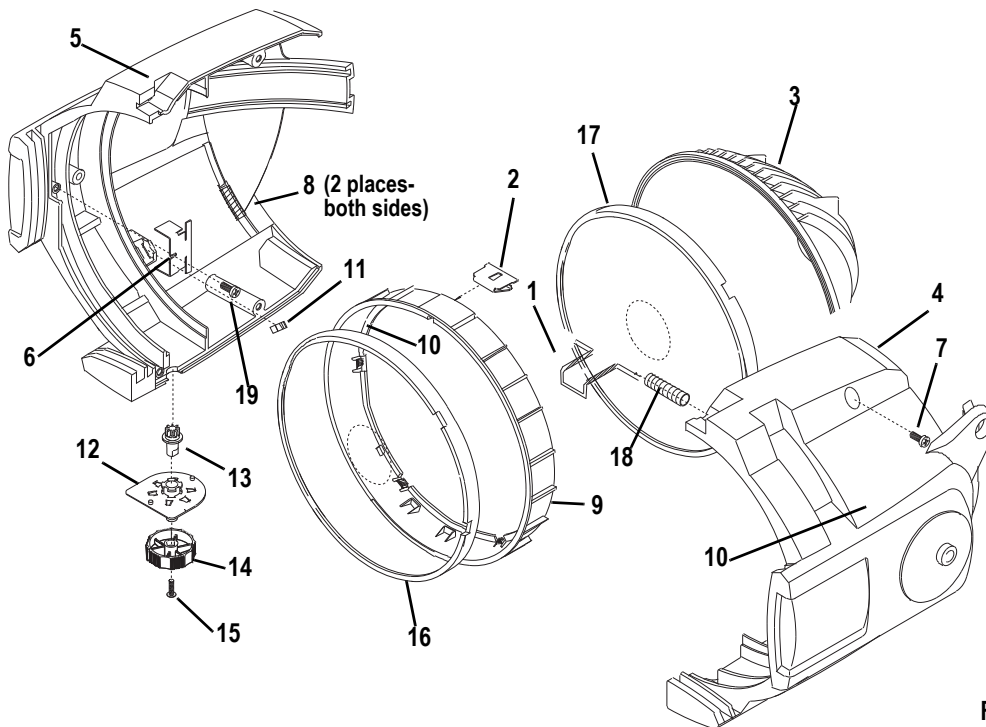

Figure 4

Reference Number	Part Number	Description	Quantity Required
1	7060A3100	Clip, gel retainer	1
2	7061A3013	Spring clip, rotator	1
3	7061A3014	Reflector, molded glass, coated, black	1
	7061A3014-1	Reflector, molded glass, coated, white	1
4	7061A3025	Barrel, right, black	1
	7061A3025-1	Barrel, right, white	1
5	7061A2019	Barrel, left, black	1
	7061A2019-1	Barrel, left, white	1
6	7061A3029	Clip, rotator, pressure	1
7	HW492	Screw, 10-32 x 5/8, PhPH, Taptite	3
8	7061A4001	Pad, silicon, reflector mount	4
9	70614012	Lens rotator, black	1
	70614012-1	Lens rotator, white	1
10	7061A4044	Label, ETC S4 PARNel, black	1
	7061A4045	Label, ETC S4 PARNel, white	1
11	7061A4020	Lens pad	4
12	7061A4013	Bushing, focus knob	1
13	7061A4014	Gear, focus knob	1
14	7061A4015	Focus knob	1
15	HW2154	Screw, PPH, 6-19 x 1.2L, 48-2 Plastite	1
16	7061A4010-2	Zoom lens, stippled/wave	1
17	7061A4010-1	Zoom lens, clear/wave	1
18	HW750	Spring, retainer	1
19	HW4145	Screw, 10-32 x 3/8, PhPH, Taptite, BO	1

## Assemble housing

Tools Required:

- Minimally padded work surface (cardboard, carpet, or rubber mat recommended)
- Phillips screwdriver



**WARNING:** *This procedure may crack or break the reflector. Always wear gloves, safety glasses, and a dust mask when performing this procedure.*

- Step 1: Install the reflector mount silicon pads (8) in the left barrel assembly (5). Install the pads in two places on both sides. See [Figure 4](#).
- Step 2: With the wave side of the lens facing toward the front of the fixture, install the clear/wave lens (17) into the rear lens track.
- Step 3: Assemble the focus knob assembly (12, 13, 14). Rotate the focus knob to the full spot position. The arrow on the focus knob will point approximately to the 11 O'clock position.
- Step 4: Place the focus knob assembly into the left barrel (5).
- Step 5: Install the lens stop (10) and the rotator spring clip (6) into the lens rotator (9).
- Step 6: Install the lens rotator (9) into the left barrel (5).
- Step 7: Install the rotator pressure clip (6) into the left barrel with screw (19).
- Step 8: Install the gel retainer clip (1) and the spring retainer (18) into the right barrel (4).
- Step 9: Attach the right barrel to the left barrel using screws (7) in three places. Hand tighten only (25 inch pounds).
- Step 10: Check that the gel clip retainer (1) moves easily into position.
- Step 11: Check for smooth rotation of the lens rotator (9).
- Step 12: Position the fixture with the front of the unit facing you, and tilted slightly down. With the wave side facing inward, install the stippled/wave lens (16) into the lens rotator (9).

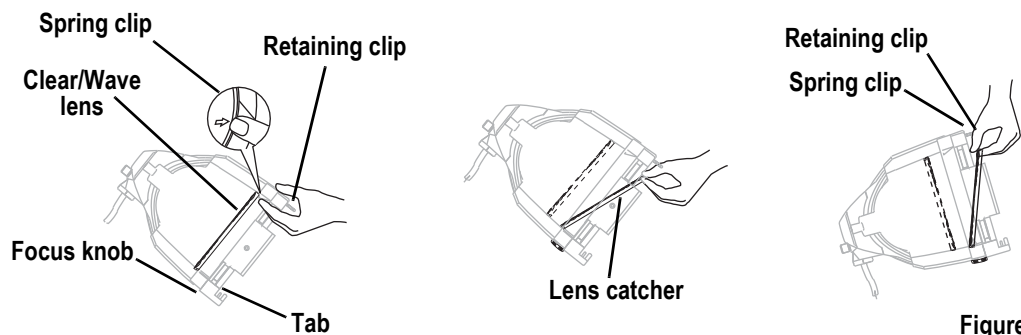

- Step 13: Rotate the focus knob to the full spot position.
- Step 14: Hold the lens by the edge and position it so the wave side faces the rear of the fixture. See [Figure 5](#).
- Step 15: From the top of the fixture, slide the lens behind the lens catchers and position its base behind the tabs on the bottom 4th lens rotator ring.
- Step 16: Gently push the top of the lens inward until it snaps behind the spring clip.

## Positioning the stippled /wave lens.

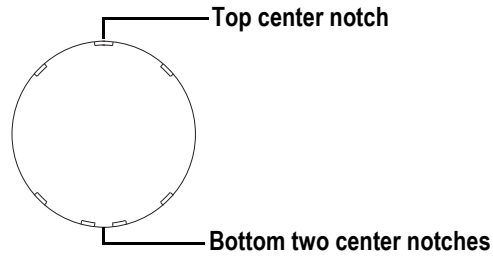

Figure 6

- Step 1: There are seven notches cut into the stippled side of the lens. Position the lens so the cluster of three notches is on top. The center notch of the cluster aligns with the spring clip on the lens retainer ring. See [Figure 6](#).
- Step 2: The bottom of the lens has a cluster of four notches. Place the two center notches behind the tabs at the bottom of the lens rotator ring.

## Cleaning the reflector



**WARNING:** *Do not use ammonia-based or other harsh commercial cleaners. Clean reflector only as directed.*

*Commercially available glass cleaning agents should be avoided as they may contain ammonia, other harsh chemical detergents or abrasive agents. These cleaners may damage the glass surface and the Anti-Reflective coatings. Do not immerse or soak the glass in any cleaning solution.*

- Step 1: Remove the lens to expose the reflector so you can access it from the front of the fixture.
- Step 2: Remove dust with a blast of oil-free air or wipe with a clean, lint-free cloth. Isopropyl alcohol, distilled water or a 50%-50% mixture of each can be used to clean the glass surface.
- Step 3: Reinstall a lens before using the fixture.

## Cleaning the lens



**WARNING:** *Do not use ammonia-based or other harsh commercial cleaners. Clean lens only as directed.*

*Commercially available glass cleaning agents should be avoided as they may contain ammonia, other harsh chemical detergents or abrasive agents. These cleaners may damage the glass surface and the Anti-Reflective coatings. Do not immerse or soak the glass in any cleaning solution.*



**Note:** The fixture must be disassembled in order to clean the rear clear/wave lens. See [Assemble housing, page 5](#) and reverse steps 12-3.

- Step 1: Remove dust with a blast of oil-free air or wipe with a clean, lint-free cloth. Isopropyl alcohol, distilled water or a 50%-50% mixture of each can be used to clean the glass surface.
- Step 2: Reassemble the fixture.











**Corporate Headquarters** ■ 3031 Pleasant View Road, P.O. Box 620979, Middleton, Wisconsin 53562-0979 USA ■ Tel +608 831 4116 ■ Fax +608 836 1736  
**London, UK** ■ Unit 26-28, Victoria Industrial Estate, Victoria Road, London W3 6UU, UK ■ Tel +44 (0)20 8896 1000 ■ Fax +44 (0)20 8896 2000  
**Rome, IT** ■ Via Ennio Quirino Visconti, 11, 00193 Rome, Italy ■ Tel +39 (06) 32 111 683 ■ Fax +39 (06) 32 656 990  
**Holzkirchen, DE** ■ Ohmstrasse 3, 83607 Holzkirchen, Germany ■ Tel +49 (80 24) 47 00-0 ■ Fax +49 (80 24) 47 00-3 00  
**Hong Kong** ■ Rm 1801, 18/F, Tower 1 Phase 1, Enterprise Square, 9 Sheung Yuet Road, Kowloon Bay, Kowloon, Hong Kong ■ Tel +852 2799 1220 ■ Fax +852 2799 9325  
**Service:** (Americas) [service@etcconnect.com](mailto:service@etcconnect.com) ■ (UK) [service@etc europe.com](mailto:service@etc europe.com) ■ (DE) [techserv-hoki@etcconnect.com](mailto:techserv-hoki@etcconnect.com) ■ (Asia) [service@etcasia.com](mailto:service@etcasia.com)  
**Web:** [www.etcconnect.com](http://www.etcconnect.com) ■ Copyright © 2007 ETC. All Rights Reserved. ■ Product information and specifications subject to change.  
**7061M2550-06.01** ■ Rev A ■ Released 08/2007