

Source Four[®] **PAR**

Assembly Guide

Production Dates: September 2004 - Present

ATTENTION: The part numbers listed in this guide may differ from the parts required for your particular Source Four fixture. Part numbers for fixtures change occasionally as parts are replaced or upgraded.

To ensure that you are ordering the proper part for your specific fixture, please contact your ETC dealer, or ETC Customer Service for assistance.

Table of Contents

Basic Assembly	1
Lamp Socket Assembly	2
Assemble lamp socket.....	3
Housing Assembly	4
Assemble housing	5
Cleaning the reflector.....	6
Cleaning the lens.....	6
Lens identification	7

ETC[®], Emphasis[®], Expression[®], Insight[™], Imagine[™], Focus[™], Express[™], Unison[®], Obsession[®] II, ETCNet2[™], EDMX[™], Source Four[®], Revolution[®], Sensor[®], and WYSILink[™] are either registered trademarks or trademarks of Electronic Theatre Controls, Inc. in the United States and other countries.

All other trademarks, both marked and not marked, are the property of their respective owners.

ETC intends this document, whether printed or electronic, to be provided in its entirety.

Basic Assembly

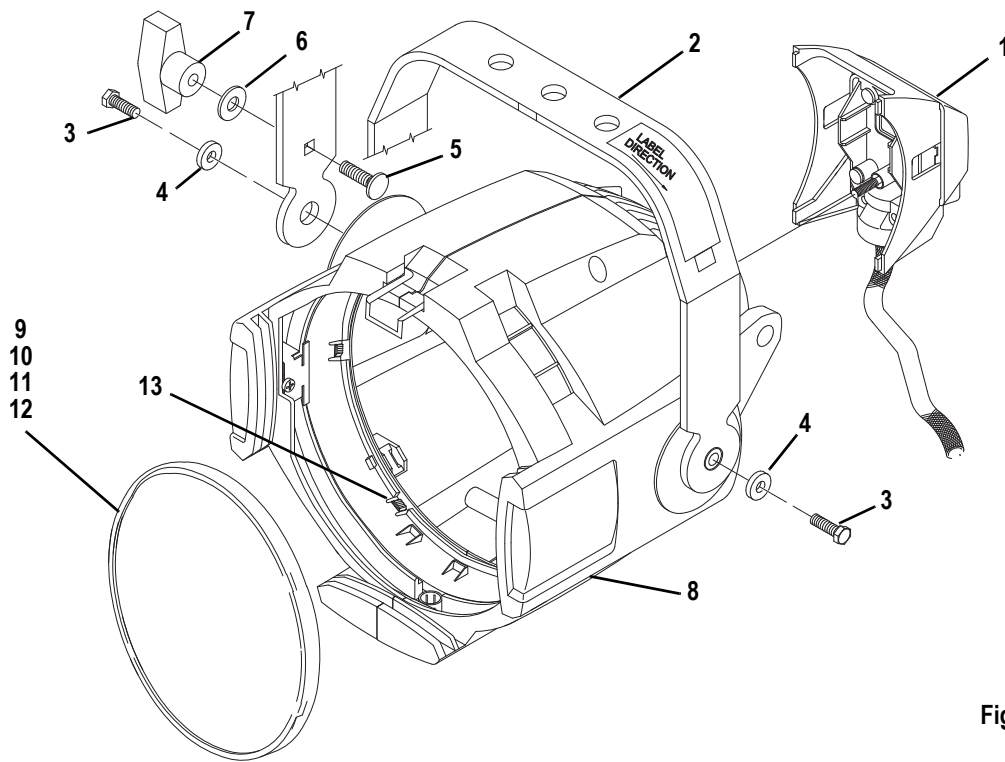

Figure 1

Reference Number	Part Number	Description	Quantity Required
1	7061A2001	Lamp socket assembly, black	1
	7061A2001-1	Lamp socket assembly, white	1
2	7061A3006	Bracket, yoke, black	1
	7061A3006-1	Bracket, yoke, white	1
3	HW5172	Bolt, hex, 1/4-20 x 1", black zinc	2
4	HW522	Washer, flat, 1/4, black zinc	2
5	HW5125	Bolt, carriage, 5/16-18, black zinc	1
6	HW5126	Washer, flat, 5/16, black zinc	1
7	HW8144	Handle, yoke knob, 5/16-18	1
8	7061A2015	Housing Assembly, EA, black	1
	7061A2015-1	Housing Assembly, EA, white	1
9	7061A4002	Lens, clear, VNSP	1
10	7061A4003	Lens, stipple, NSP	2
11	7061A4005	Lens, medium flood, MFL	1
12	7061A4006	Lens, wide flood, WFL	1
13	7061A4029	Lens stop	1

Lamp Socket Assembly

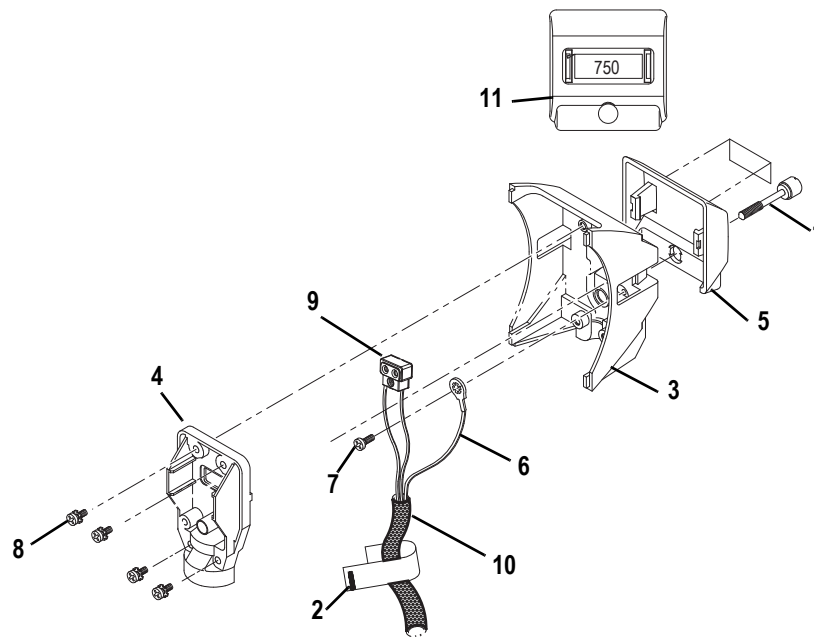

Figure 2

Reference Number	Part Number	Description	Quantity Required
1	7060A3025	Screw, 1/4-20 x 1.55, knurled	1
2	7060A4019	Label, Fixture Warning	1
3	7061A3023	Burner, casting, black	1
	7061A3023-1	Burner, casting, white	1
4	7061A3024	Strain relief, black	1
	7061A3024-1	Strain relief, white	1
5	7061A4011	Focus handle, black	1
	7061A4011-1	Focus handle, white	1
6	7061B7002	Ground Wire, 48"	1
7	HW2182	Screw, 6-32 x 1/4, PhPh, Taptite, zinc	1
8	HW3105	Screw, 8-32 x 1/2, PhPh, Taptite, SEMS	4
9	M706	Complete TP 22 CLCM assembly	1
10	W6195	Sleeve, fiberglass, 39", black	1
	W689-1	Sleeve, fiberglass, 39", white	1
11	7060A4094	Label, 750W, handle, black	1
	7060A4095	Label, 750W, handle, white	1

Assemble lamp socket

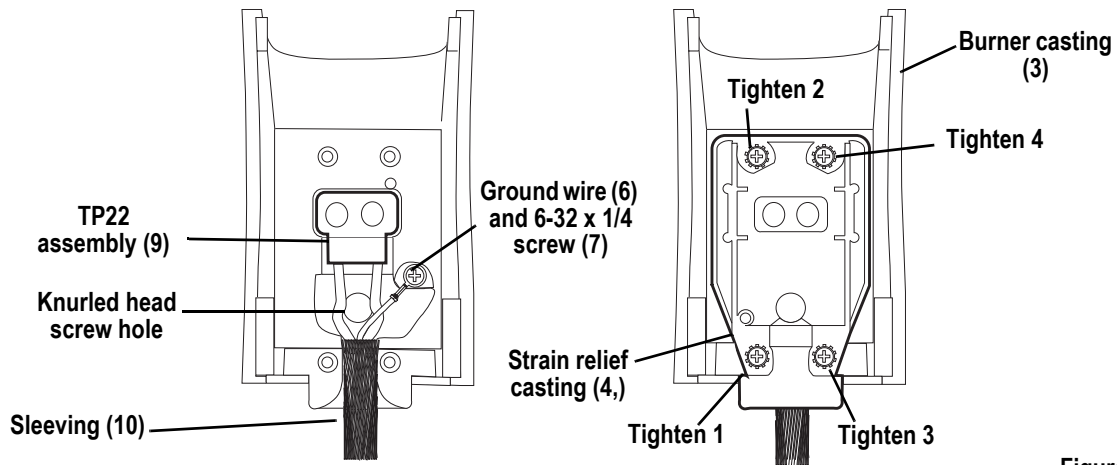

Figure 3

Tools Required:

- #2 Phillips screwdriver

Step 1: Install the ground wire (6) and the TP22 assembly (9) in the sleeving (10). See [Figure 3](#).

Step 2: Snap the focus handle (5) onto the burner (3). See [Figure 2](#).

Step 3: Secure the ground wire lug (6) onto the burner casting (3) using screw (7).

Step 4: Place the TP22 assembly (9) into the burner casting (3). See [Figure 3](#).



Note:

Position the wires with the green ground wire on top of the two TP22 white leads. Make sure the green ground wire is not touching any part of the burner casting.

Step 5: Insert the screws (8) into the four positions in the strain relief casting (4). See [Figure 3](#).

Step 6: Position the sleeving assembly (10) as shown in [Figure 3](#). Fold the sleeving so it fits cleanly in the slot between the burner and the strain relief.

Step 7: Place the strain relief (4) on the burner casting (3). Loosely attach the screws (8). The TP22 assembly (9) must be centered in the strain relief opening (4). See [Figure 3](#).

Step 8: To guard against stripping the screws, tighten them in the order shown in [Figure 3](#).

Step 9: Make sure the focus handle is secure, then insert the knurled head screw (1) through the handle (5) into the burner casting (3). Tighten securely.

Housing Assembly

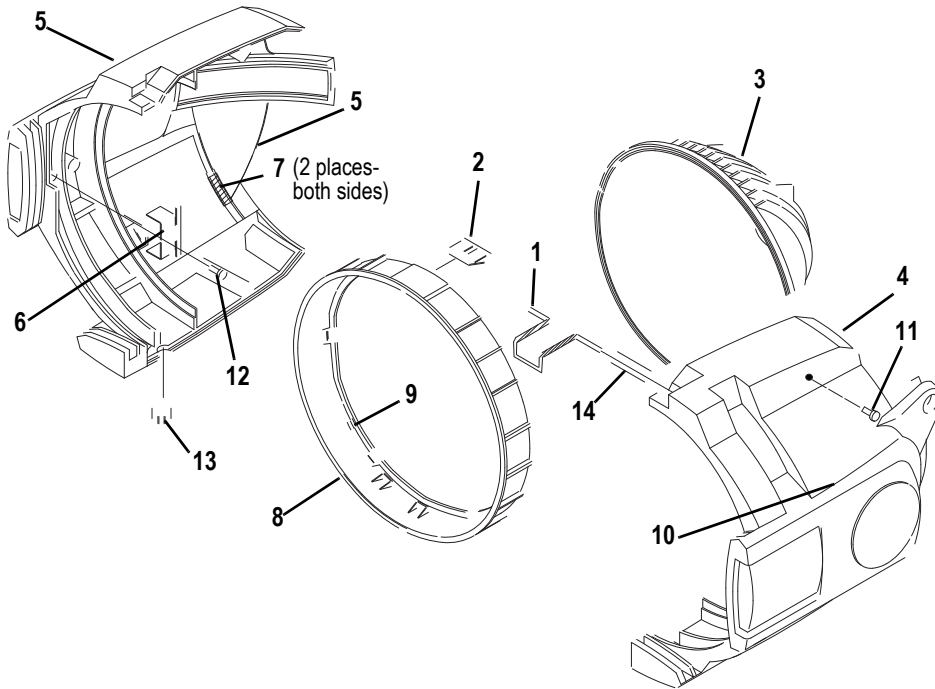

Figure 4

Reference Number	Part Number	Description	Quantity Required
1	7060A3100	Clip, gel retainer	1
2	7061A3013	Spring clip, rotator	1
3	7061A3014	Reflector, molded glass, coated, black	1
	7061A3014-1	Reflector, molded glass, coated, white	1
4	7061A3025	Barrel, right, black	1
	7061A3025-1	Barrel, right, white	1
5	7061A2019	Barrel, left, black	1
	7061A2019-1	Barrel, left, white	1
6	7061A3029	Clip, rotator, pressure	1
7	7061A4001	Pad, silicon, reflector mount	4
8	7061A4012	Lens rotator, black	1
	7061A4012-1	Lens rotator, white	1
9	7061A4029	Lens stop	1
10	7061A4030	Label, ETC S4 PAR, black	1
	7061A4030-1	Label, ETC S4 PAR, white	1
11	HW492	Screw, 10-32 x 5/8, PhPH, Taptite	3
12	HW4145	Screw, 10-32 x 3/8, PhPH, Taptite, BO	1
13	HW6128	Plug, focus knob, black	1
	HW6128-1	Plug, focus knob, white	1
14	HW750	Spring, retainer	1

Assemble housing

Tools Required:

- Minimally padded work surface (cardboard, carpet, or rubber mat recommended)
- Phillips screwdriver



WARNING: *This procedure may crack or break the reflector. Always wear gloves, safety glasses, and a dust mask when performing this procedure.*

- Step 1: Install the reflector mount silicon pads (7) in the left barrel assembly (6). Install the pads in two places on both sides. See [Figure 4](#).
- Step 2: Install the lens stop (9) and rotator spring clip (2) into the lens rotator (8). Install the lens rotator into the left barrel (5).
- Step 3: Install the rotator pressure clip (6) into the left barrel (5) and attach using screw (12).
- Step 4: Install the gel retainer clip (1) and the spring retainer (14) into the right barrel (4).
- Step 5: Install the reflector (3) into the left barrel (5). Align the rib on the reflector with the left barrel pocket as shown in [Figure 5](#).
- Step 6: Attach the right barrel (4) to the left barrel (5) using three screws (11). Hand tighten only (25 in. lbs.).
- Step 7: Clean reflector. See [“Cleaning the reflector” on page 6](#).
- Step 8: Check for ease of movement of the gel clip retainer (1). The clip should latch into the left barrel in the down position and be free of binding.
- Step 9: Check for smooth rotation of the lens rotator (8).
- Step 10: Snap the focus knob plug (13) into the bottom of the fixture.
- Step 11: Attach label (10) onto the left barrel as shown in [Figure 5](#).

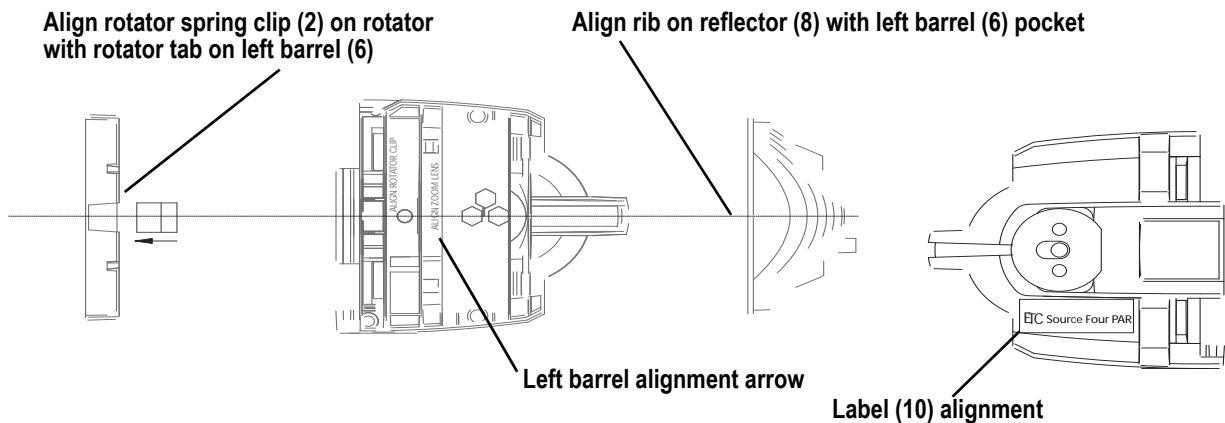

Figure 5

- Step 12: Hold the lens by the edge and position it so the wave side faces the rear of the fixture. See [Figure 6](#).
- Step 13: From the top of the fixture, slide the lens behind the lens catchers and position it behind the tabs on the bottom of the lens rotator ring.
- Step 14: Gently push the top of the lens inward until it snaps behind the spring clip.

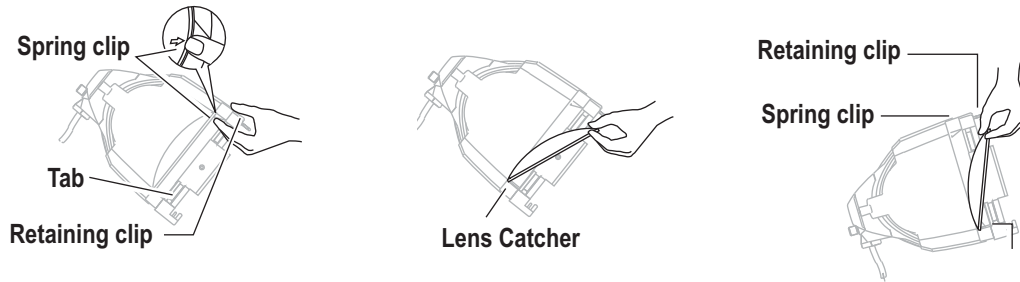

Figure 6

- Step 15: Install the lamp socket assembly (See [“Assemble lamp socket” on page 3.](#)) to the barrel housing assembly and secure with brass knurled screw on rear of lamp socket assembly.

Cleaning the reflector



WARNING: *Do not use ammonia-based or other harsh commercial cleaners. Clean reflector only as directed.*

Commercially available glass cleaning agents should be avoided as they may contain ammonia, other harsh chemical detergents or abrasive agents. These cleaners may damage the glass surface and the Anti-Reflective coatings. Do not immerse or soak the glass in any cleaning solution.

- Step 1: Remove the lens to expose the reflector so you can access it from the front of the luminaire.
- Step 2: Remove dust with a blast of oil-free air or wipe with a clean, lint-free cloth. Isopropyl alcohol, distilled water or a 50%-50% mixture of each can be used to clean the glass surface.
- Step 3: Reinstall a lens before using the luminaire.

Cleaning the lens



WARNING: *Do not use ammonia-based or other harsh commercial cleaners. Clean lens only as directed.*

Commercially available glass cleaning agents should be avoided as they may contain ammonia, other harsh chemical detergents or abrasive agents. These cleaners may damage the glass surface and the Anti-Reflective coatings. Do not immerse or soak the glass in any cleaning solution.

Remove dust with a blast of oil-free air or wipe with a clean, lint-free cloth. Isopropyl alcohol, distilled water or a 50%-50% mixture of each can be used to clean the glass surface.

Lens identification

Lenses for the Source FourPAR come in four varieties. The type or beam spread can be identified by the texture of the lens.

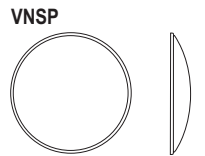

VNSP
Very narrow spot
Clear glass
15° Round beam shape

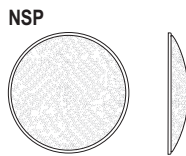

NSP
Narrow spot
Stipple glass (slight diffuse texture)
19° Round beam shape

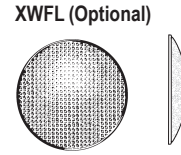

XWFL (Optional)
Extra-wide, or buxom, lens
Molded, borosilicate lens, multi-faceted
60° Round beam shape

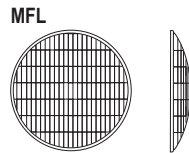

MFL
Medium flood
Fewer facets, sized 6 x 22mm
21° x 34° Oblong beam shape

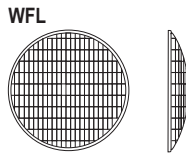

WFL
Wide flood
Many facets, sized 6 x 12mm
30° x 51° Oblong beam shape

Figure 7



Corporate Headquarters ■ 3031 Pleasant View Road, P.O. Box 620979, Middleton, Wisconsin 53562-0979 USA ■ Tel +608 831 4116 ■ Fax +608 836 1736
London, UK ■ Unit 26-28, Victoria Industrial Estate, Victoria Road, London W3 6UU, UK ■ Tel +44 (0)20 8896 1000 ■ Fax +44 (0)20 8896 2000
Rome, IT ■ Via Ennio Quirino Visconti, 11, 00193 Rome, Italy ■ Tel +39 (06) 32 111 683 ■ Fax +39 (06) 32 656 990
Holzkirchen, DE ■ Ohmstrasse 3, 83607 Holzkirchen, Germany ■ Tel +49 (80 24) 47 00-0 ■ Fax +49 (80 24) 47 00-3 00
Hong Kong ■ Rm 1801, 18/F, Tower 1 Phase 1, Enterprise Square, 9 Sheung Yuet Road, Kowloon Bay, Kowloon, Hong Kong ■ Tel +852 2799 1220 ■ Fax +852 2799 9325
Service: (Americas) service@etcconnect.com ■ (UK) service@etc europe.com ■ (DE) techserv-hoki@etcconnect.com ■ (Asia) service@etcasia.com
Web: www.etcconnect.com ■ Copyright © 2007 ETC. All Rights Reserved. ■ Product information and specifications subject to change.
7061M2500-06.01 ■ Rev A ■ Released 08/2007