

Preset 10 Ethernet Interface Configuration & Owner's Manual

model: PRE10E-A



Doug Fleenor Design, Inc.
396 Corbett Canyon Road
Arroyo Grande, CA 93420
(805) 481-9599 Voice and FAX

Manual Revision 0
September 2018

PRODUCT OVERVIEW

The Preset Ten Ethernet (PRE10E-A) wall station plays back snapshots of sACN (E1.31) on four universes. The simple front interface allows the user to control 2,048 individual slots with the push of a button. Static snapshots from any sACN capable console record into the ten presets. Snapshot play back may be used as an alternative to a more complex console, or operate along with that same console. Various lockout topologies make the PRE10E-A ideal in venues requiring untrained users to control fixtures typically accessed by a more complex console. The PRE10E-A supports Power over Ethernet (PoE – 802.3af) or a 24-48VDC power input. Station configuration takes place on a rear facing user interface. Multiple stations may operate on the same universes, and stations operating on different universes may operate on the same Local Area Network (LAN)

INSTALLATION

The PRE10E-A installs into a standard two gang electrical wall box. Minimum dimensions on the inside of the electrical box are 3.6”h X 2.9w” x 1.4”d. Data input and output takes place over the RJ45 jack. For best possible data rates, a cable capable of Fast Ethernet (100BASE-TX) is required. The cable must connect the PRE10E-A to an Ethernet LAN that contains the console and receiving devices.

Power may enter the unit using the Ethernet cable when a Power over Ethernet switch or injector are used. When utilizing PoE only one cable is required. Installations not utilizing PoE can use the Auxiliary 24-48VDC input.

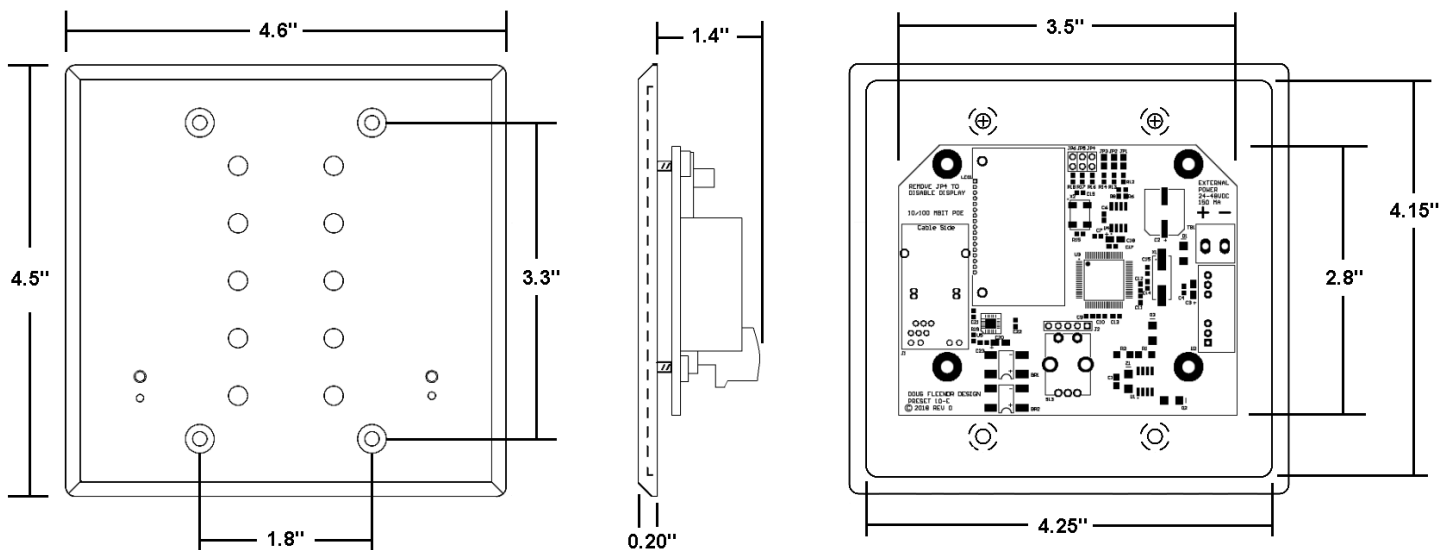

SYSTEM TOPOLOGY

Both Single Station and Multistation system designs are possible with the PRE10E-A. A simple system may consist of a single console, PRE10E-A, and receiving device.

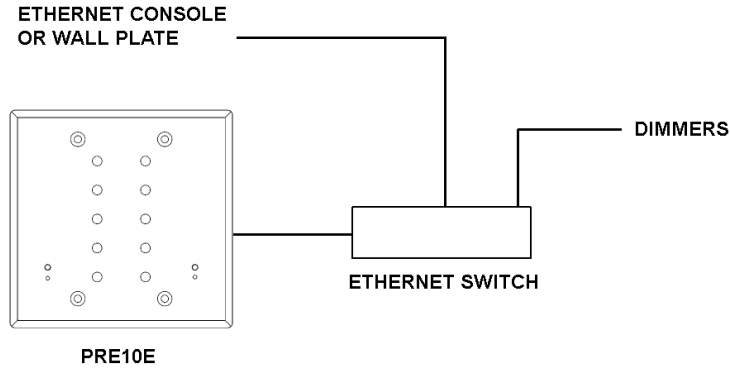

A more complex system may have PRE10E-A stations at multiple locations in a building.

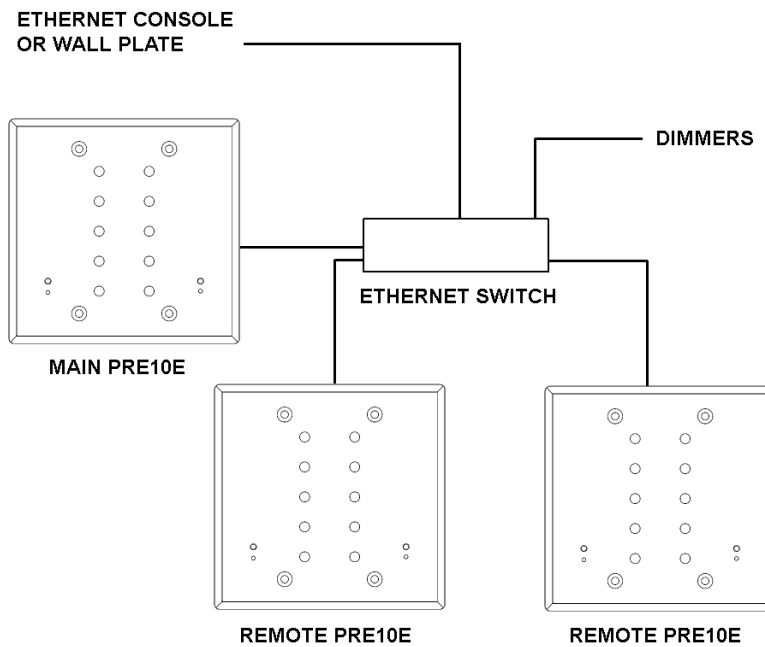

Data transport between each sACN capable device takes place using standard Ethernet hardware that supports multicast traffic. The above diagrams utilize a single Ethernet switch for simplicity. Any network hardware constituting a properly configured LAN may replace the Ethernet Switch blocks above.

REAR INTERFACE

The PRE10E-A has a set of rear mounted controls that are accessed during initial commissioning of the wall station. The rear interface changes network settings, lockouts and button behavior. Once setup is complete, this interface remains facing into the two gang wall box and is not accessed by users changing presets on the front interface.

The rear interface has a monochrome graphical Liquid Crystal Display (LCD), and a rotary encoder with a button. The LCD displays the configuration pages which are edited by turning the encoder, and pressing the button. The configuration page changes when the page change symbol is highlighted [$<$ $>$] and the encoder wheel is turned. Depressing the encoder shaft acts as a button to toggle between the editable fields on the screen. A highlight appears in the background of the editable field, at which point the wheel changes the highlighted value. In addition to the LCD and encoder based configurations, three jumpers select settings that are not accessed in the LCD menus.

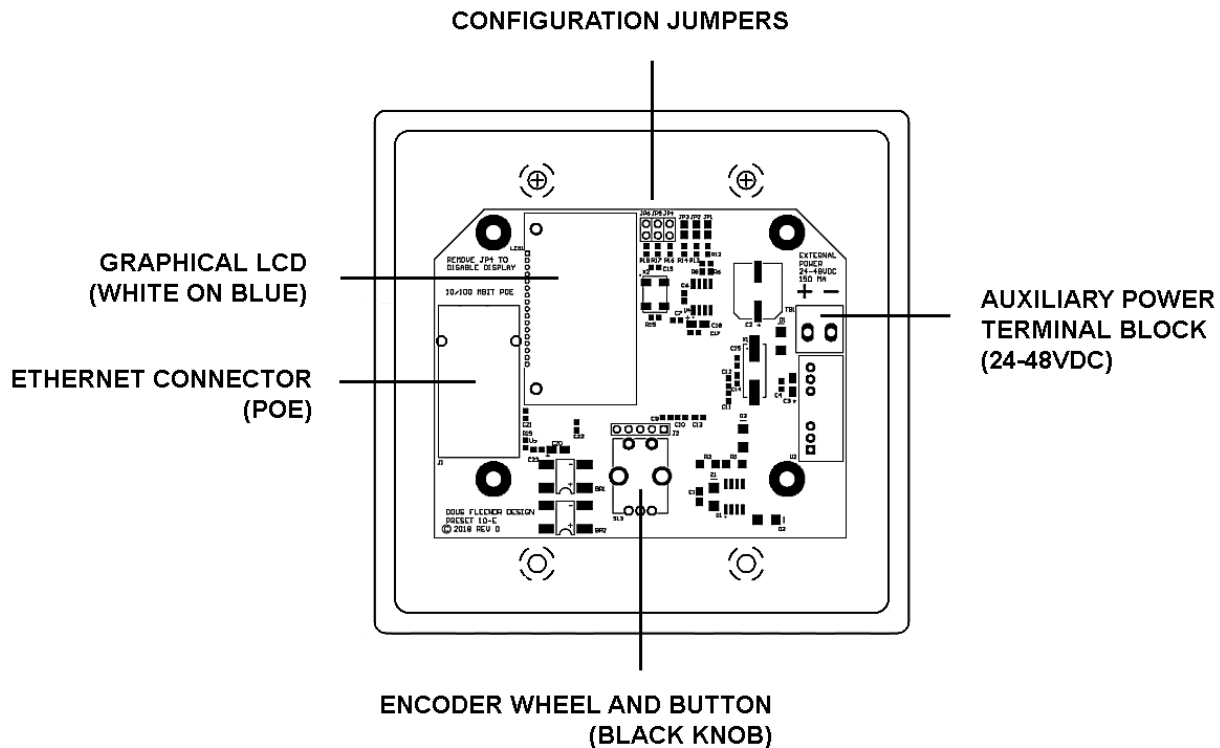

Using the LCD, encoder, and jumpers, an installer can commission the PRE10E-A. Initial commissioning consists of setting the following configuration options:

DHCP

Turns Dynamic Host Configuration Protocol (DHCP) On or Off. DHCP servers, such as a router, will issue an IPv4 address to the PRE10E-A when connected on the same Local Area Network. With a DHCP address issued, the PRE10E-A will not be able to alter its own IPv4 address.

IPv4

The Internet Protocol Version Four (IPv4) address is edited here when DHCP is off.

SUBNET MASK

IPv4 Subnet mask bits are set here when DHCP is off.

UNIVERSE

Available sACN universes range from 1 to 63,999. The default starting universe for the PRE10E-A is universe 1, which can be altered in this menu. The selected starting universe is the first of four universes. For example, a starting universe of 6 gives the PRE10E-A control of universes 6, 7, 8 and 9. Since each universe contains 512 slots, this gives the PRE10E-A control of up to 2,048 slots.

PRIORITY

sACN uses a priority value to instruct receiving devices on which stream takes precedence. Receivers may merge equal priority streams if supported. This field becomes useful in conjunction with no lockout mode to allow for 'automatic' switch over when a console powers down. Priority values range from 1 to 200, with 1 being the lowest priority and 200 being the highest priority. The default priority for the PRE10E-A is set to 100 as standard.

LOCKOUT

Two options provided here are Standard, and No Lockout. When the PRE10E-A sees incoming streams on any incoming universe within its addressed universe range, in Standard lockout mode, it stops transmitting on all four universes. In No Lockout mode, transmission does not stop, and priority handling in the fixtures determines which transmitter produces light levels. Default lockout behavior is Standard.

MULTISTATION

SINGLE: Used when only one PRE10E-A is in the system. Single station mode is the default Multistation setting.

MAIN: Used when multiple stations are in one system. A main station transmits the sACN data, holds stored looks and exchanges configuration packets with remote stations. Only the main station may record presets, and set times.

REMOTE: When more than one station is on a universe, one must be set as a main, and all others set as remote stations with the same universe number. The remote stations exchange polling information with the main station, allowing button presses at multiple entrances to track through the whole system.

BUTTONS

RADIO: Button presses fade between presets, one preset is active at a time.

POPO: Piles on presets allowing more than one on at a time. In this pile-on mode, the PRE10E-A operates in a Highest Takes Precedence (HTP) fashion, outputting the highest value per slot of the active presets.

DATA

Displays the value of the first slot of the first universe being received by the PRE10E-A. The Data page does not display data transmitted by the PRE10E-A. This is provided as a system diagnostic and troubleshooting aide.

JUMPER SETTINGS

The remaining configuration options are not accessed using the LCD and encoder wheel. Instead these options are accessed by removing or applying a jumper.

JP4 - Rear Lockout – Removal of the JP4 Jumper locks out the rear encoder input and display output. The LCD image and backlight turn off. Reapplication of the JP4 Jumper re-enables the LCD and encoder.

JP5 - Force Defaults – All configuration options accessed through the LCD and encoder are set to default by the following process:

1. Power Down PRE10E-A
2. Remove *JP5*
3. Power up PRE10E-A
4. Wait 5 seconds
5. Replace *JP5*

For a listing of each default setting, see the table below.

Option	Default Setting
DHCP	True
IPv4	10.10.10.10
Subnet Mask	255.0.0.0
Universe	1
Priority	100

Lockout	Standard
Multistation	Single
Buttons	Radio

JP6 - Record Lockout – With *JP6* removed, the recessed record button on the front panel will no longer allow the recording of presets. Editing of fade times is also disabled. With *JP6* installed recording and editing of fade times take place as described in the front interface section.

FRONT INTERFACE

The PRE10E-A has a front interface where the majority of user interaction takes place. The front interface has buttons and LEDs involving playback, recording, and fade time. Using the front interface, a user can select an active preset or determine a lockout condition. The recessed *RECORD* and *FADE TIME* buttons require a small blunt object, such as a paper clip.

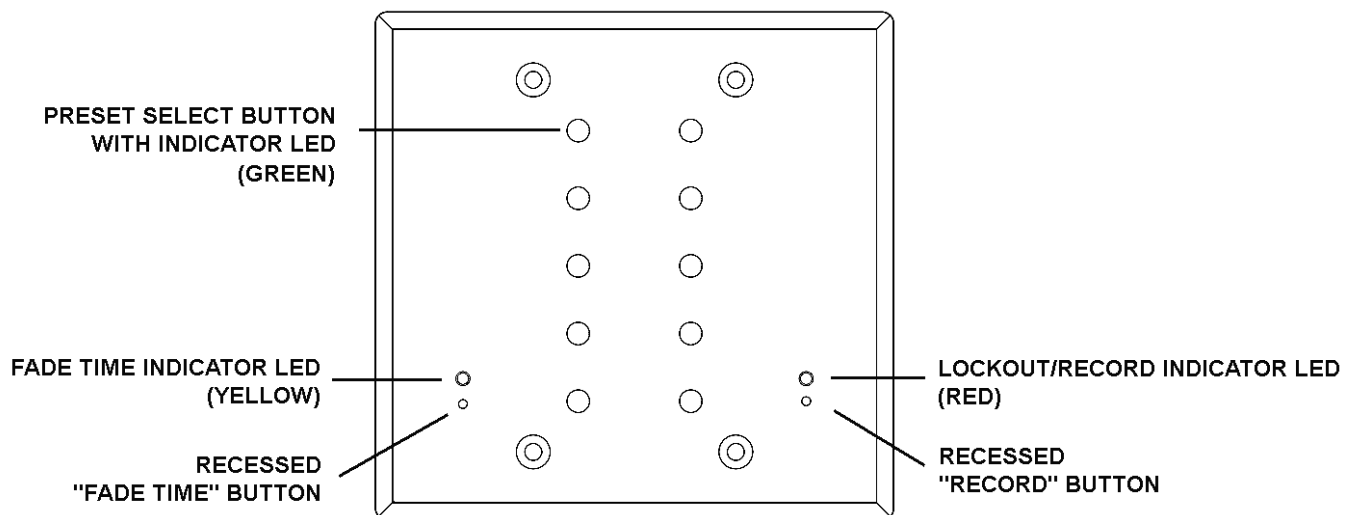

PLAYBACK OF PRESETS

The PRE10E-A transmits presets when not locked out. When the PRE10E-A outputs a preset, an associated green indicator LED will illuminate the button cap. In *STANDARD* lockout mode, the PRE10E-A will darken all active preset indicators, and show only a red indicator LED. In *NO LOCKOUT* mode, the playback happens all the time, and the red LED indicates only the receipt of data. When shipped, the PRE10E-A will have its lockout setting as *STANDARD*. Whenever one or more of the indicator LEDs are on, a user can expect playback.

The *BUTTONS* setting, found on the rear LCD, augments the front panel playback behavior. There are two options for this setting: *RADIO* and Push-On-Push-Off (*POPO*).

In *RADIO* mode the station will only allow one active preset at a time. Pressing a non-illuminated button will begin a crossfade from the currently active preset to the newly activated preset. The time taken to fade from the current preset to the new preset is taken from the newly selected preset. The LED indicator for the new preset becomes illuminated, and the LED indicator for the former preset becomes dark. Once the fade has completed, it will remain in that preset (static) until another preset is selected.

In *POPO* mode each snapshot piles on in a highest takes precedence merge with all other active presets. Each active preset will have an illuminated button cap. When a preset select button is momentarily pressed, the current output will fade to the newly modified merged set of presets using the fade time associated with the selected preset. The fade will begin when a preset is turned on and when a preset is turned off.

In both *RADIO* and *POPO* mode, whenever a fade takes place, the yellow *FADE TIME INDICATOR* led will illuminate.

Note:

- If one or more static presets are active at the time power is lost, the PRE10E-A will return to the last active preset(s) when power is restored. The formerly active preset(s) will fade in completely after eight seconds.

RECORDING PRESETS

In order to record preset levels, the PRE10E-A must be connected to an sACN source. When less than 2,048 slot levels are received, a level of 0% will be stored for all slots above those received.

Note:

- For predictable results, avoid recording when the sACN levels are changing.
- Recording of presets must be done from a station configured as MAIN or SINGLE.

1. Using the primary sACN source, set a “look” to be recorded.
2. Using a small blunt object (e.g. paper clip), momentarily depress the RECORD MODE recessed button located on the bottom most right of the PRE10E-A. The red LED above the recessed button will begin to flash. If you decide after depressing the RECORD MODE button that you do not wish to make an edit, depress the RECORD MODE button a second time. The red LED will no longer flash and no changes will have been made.

3. Momentarily depress the PRESET SELECT button of the preset number you wish to record.
4. Upon releasing the PRESET SELECT button, the red LED will no longer flash. This indicates recording is complete.

Repeat steps 1 through 4 until you have recorded as many presets as required, up to ten total.

RECORDING PRESET CROSSFADE TIME

A crossfade is a fade where the new preset levels entirely replace the previous levels. Each of the ten presets can have its own unique crossfade time. Crossfade times default to two seconds.

Note:

- Crossfade times range from a minimum of 0 seconds to a maximum of 999 seconds (16 minutes and 39 seconds).

To enter a crossfade time:

1. Disconnect the PRE10E-A from any sACN sources on the same universes as the PRE10E-A.
2. Press the button of the preset you wish to edit. The green preset indicator LED will illuminate.
3. Using a small blunt object (e.g. paper clip), momentarily depress the TIME SETTING MODE recessed button located on the bottom most left of the PRE10E-A. The green LED indicator of the preset you selected to edit and the yellow time LED above the recessed button that was just depressed will now flash. You will have ten seconds to set the crossfade time. If you decide after depressing the TIME SETTING MODE button that you do not wish to make an edit, simply wait ten seconds or depress the TIME SETTING MODE button a second time. No changes will have been made.
4. Enter the time in seconds using the PRESET SELECT buttons. Use PRESET SELECT button 10 (OFF) to enter a zero (e.g. 120 seconds is entered by pressing PRESET SELECT button 1 followed by 2 then OFF). The time setting command is completed by one of three methods:
 - a. Enter a three-digit time. The TIME SETTING MODE will exit upon the entry of the third digit. The green preset indicator LED will illuminate steadily and the yellow time LED will go off, indicating success. A one or

two digit time may be entered with leading zeros (e.g. five seconds as 005 or PRESET SELECT buttons OFF, OFF, 5).

- b. Enter a one or two digit time followed by pressing the TIME SETTING MODE button. The green preset indicator LED will illuminate steadily and the yellow LED will go off, indicating success.
- c. Enter a one or two digit time and wait for ten seconds for the time setting mode to exit automatically. The green preset indicator LED will illuminate steadily and the yellow time LED will go off, indicating success.

Warranty

Products manufactured by Doug Fleenor Design carry a five year parts and labor warranty against manufacturing defects. It is the customer's responsibility to return the product to Doug Fleenor Design (at the customer's expense) for service. Doug Fleenor Design will repair the unit and return it to the customer (at Doug Fleenor Design's expense). If a trip is necessary to the customer's site to solve a problem, the expenses of the trip must be paid by the customer.

Note that this warranty is against Manufacturing Defects. It does not include damage due to abuse, misuse, negligence, accident, alteration or faulty repair other than by Doug Fleenor Design, or "acts of God". In addition, Doug Fleenor Design shall have no further obligation if products are subjected to operating conditions outside of the product's range specified in the user's guide or product specifications.

Most non-warranty repairs are made for a fixed \$30.00 fee, plus shipping.