



## NEO Lighting Control Console

The introduction of the NEO lighting control console marks a new chapter in the evolution of control. This console allows the ability to seize light; to grab, move, change position, color and motivate the lighting design simply and effectively. The NEO lighting control console is the closest that a designer can get to actually touching the light; encompassing the dreams and aspirations of both professionals and amateurs alike. The NEO lighting control console starts with the inclusion of many timesaving features, allowing the user to program faster and more accurately.

Icons and Shutter controls are represented graphically on the display, saving time and presenting meaningful data to the operator. Floating Windows allow the operator to configure their views their way, making it easier to find information. Effects are revolutionized, with "Time Line" features, allowing drag and drop to create that perfectly timed sequence.

The show is even secured on a "Mission Critical" grade SQL server, ensuring no data loss in those critical moments. Boot time is massively reduced with high speed solid state disk drives, making the NEO lighting control console robust for everyday and touring use.

With individually controlled back lit keys, motorized faders, user security system, pixel mapping and media playback: we think you will find the NEO lighting control console a worthy successor to a proud history of iconic consoles that have had the honor of bearing the Strand Lighting and now Philips Strand Lighting name.



**NEO Lighting Control Console**  
(shown with optional monitor - monitor sold separately)

### Features

- Up to 100 Universes of DMX per Console
- 10 Motorized Submasters
- Motorized A/B Playback Faders
- 5 Motorized Multi-Function Faders
- Dual Motorized Grand Masters
- Individually Controlled Backlit Keys
- 4 Indented Push Encoders
- Color LCD Screens for Encoder Assignment
- Keyboard drawer with storage with USB
- Touchscreen capable interface
- Unlimited Cues, Cue Lists, Groups, Palettes, Effects, and Macros
- Tempo Button
- Tracking, Cue Only and Hybrid Tracking Programming
- Flexible Shortcut System
- Generic Palettes
- Time Line Effects
- Pixel Mapping
- Media Playback
- Multi-User
- Tracking Backup
- User security system (login)
- Timed Events with sunrise/sunset
- Telnet Interface
- Web Server Hosting
- Android / iOS Remotes
- Undo History
- Visual Timecode Editor
- Power Monitor
- Color and Position Paths per Cue
- Blind Pre-Visualization
- Magic Sheet Layout
- 4 DMX Out Ports / 1 DMX In Port / 2 Network Ports
- 3 Video Outs (HDMI / VESA Display Port / DVI)
- MIDI Out / In
- SMPTE Out / In
- USB 3.0 and USB 2.0 Ports
- 2 COM Ports
- 2 XLR Ports for Console Lights
- Tablet Storage

**PHILIPS**  
**Strand Lighting**

### SPECIFICATION SUBMITTAL

CONSULTANT: <input type="text"/>	PROJECT NAME: <input type="text"/>	MODEL NUMBER   QUANTITY: <input type="text"/> <input type="text"/> <input type="text"/> <input type="text"/> <input type="text"/> <input type="text"/>
DATE: <input type="text"/>	PROJECT NUMBER: <input type="text"/>	APPROVED BY: <input type="text"/>

Console Features

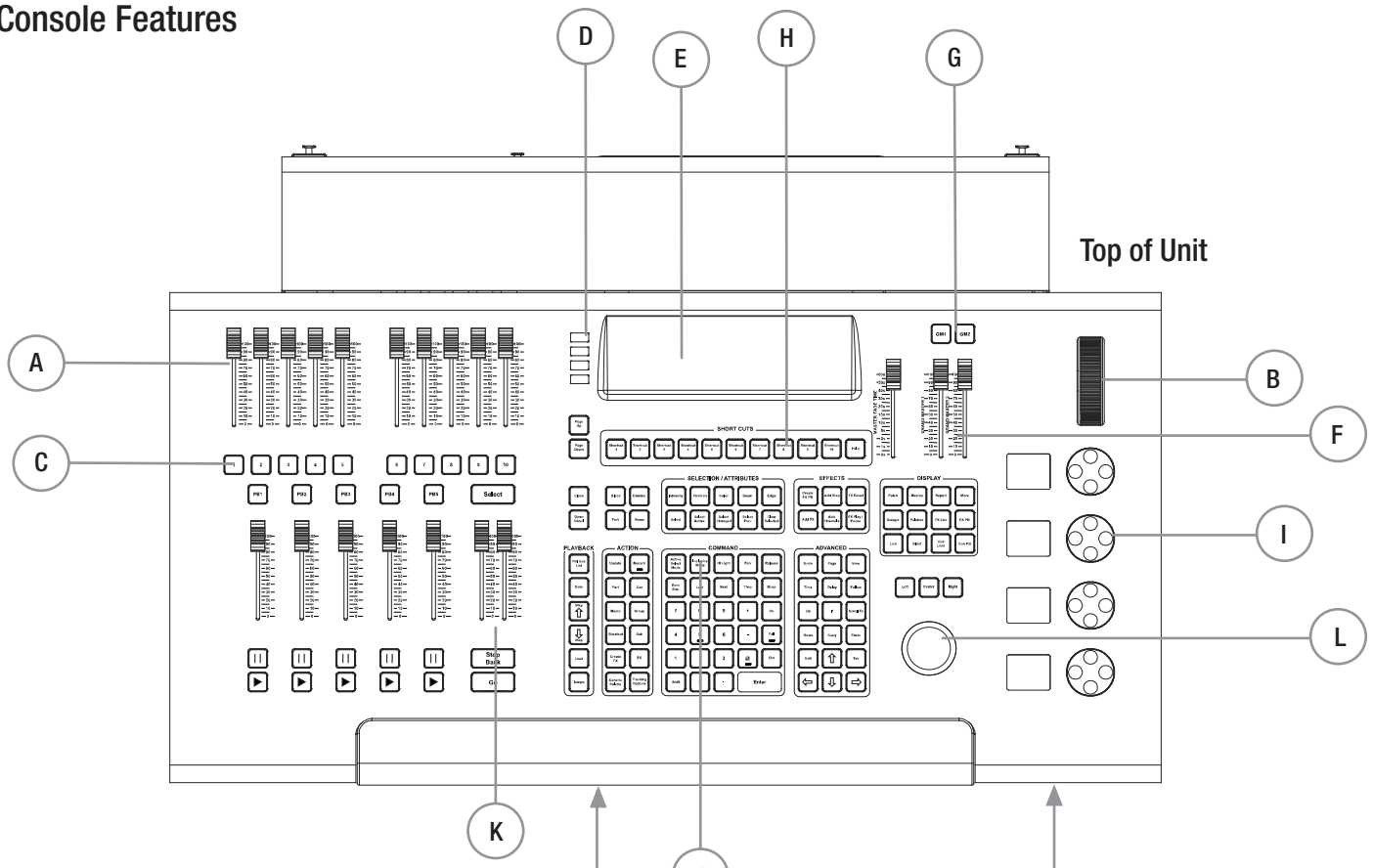

Pull out Keyboard Drawer with Phone Storage and USB Charger (phone by others)

1/8-inch Mini Headphone Jack (headphone by others)

Legend

- |   |  |
|---|--|
| A. Motorized Faders / Submasters                        | G. Black Out Buttons                                     |
| B. Level Wheel  | H. Shortcuts (10 each)                                   |
| C. 10 Bump Buttons                                      | I. Encoders with Encoder Status (4 each)                 |
| D. USB Port (showfile storage, USB key sold separately) | J. Programming Buttons                                   |
| E. Tablet Well with USB Power (tablet by others)        | K. A/B Playback Controls (with Go and Stop/Back buttons) |
| F. Grand Masters (2)                                    | L. Track Ball  |

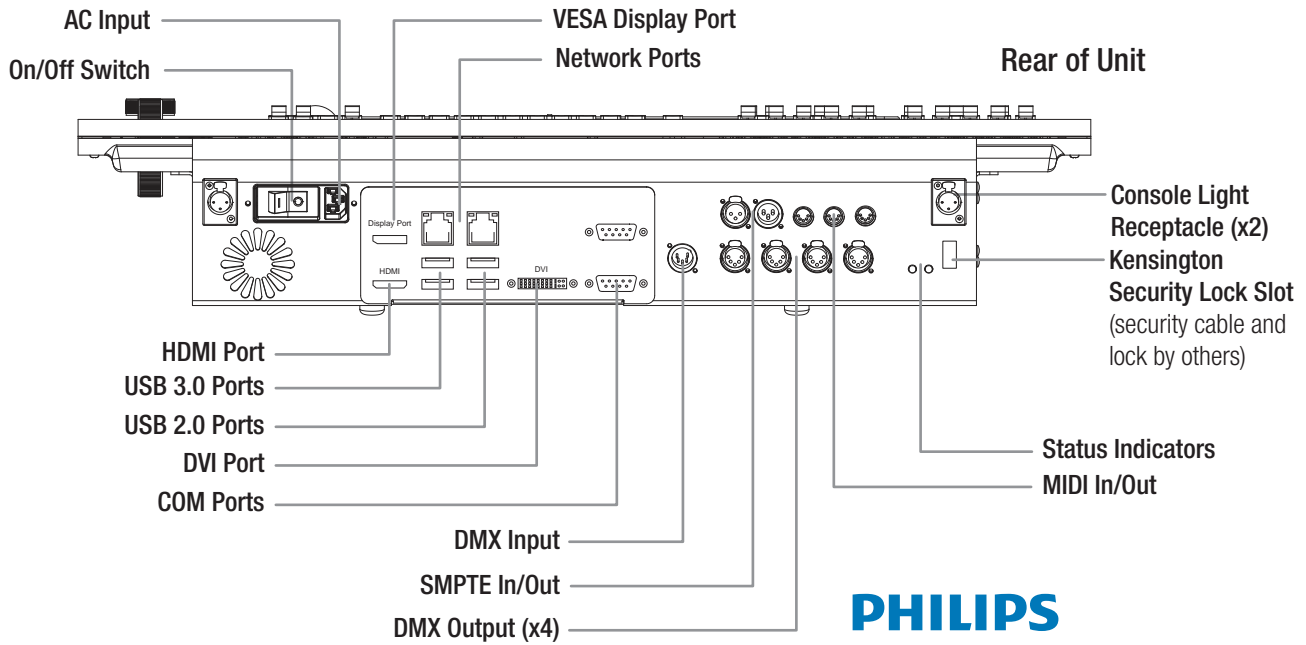

### Philips Advantage DMX

Every NEO lighting control console also benefits from the all new Philips Advantage DMX model. This concept allows you to patch Philips Entertainment and Color Kinetics brand luminaires without consuming the console's purchased DMX outputs. It does not matter if you own or rent the luminaires; as long as the one of the supported Philips brands. With Philips Advantage DMX, you can control thousands of Philips luminaires at no additional cost or output license limitations.

#### Philips Advantage DMX Overview (example):

- A NEO lighting control console is purchased with 1 universe of 512 DMX outputs.
- The purchased universe of 512 DMX outputs is patched to dimmers or other DMX-controlled products.
- Philips Entertainment Group luminaires (sold separately) are patched to any other DMX universe. Philips Entertainment Group luminaires (regardless if you own or rent them) will not count against any of the purchased channels unless patched to the purchased DMX universe.



NEO Lighting Control Console  
(shown with keyboard drawer open - monitor sold separately)

### Product Dimensions

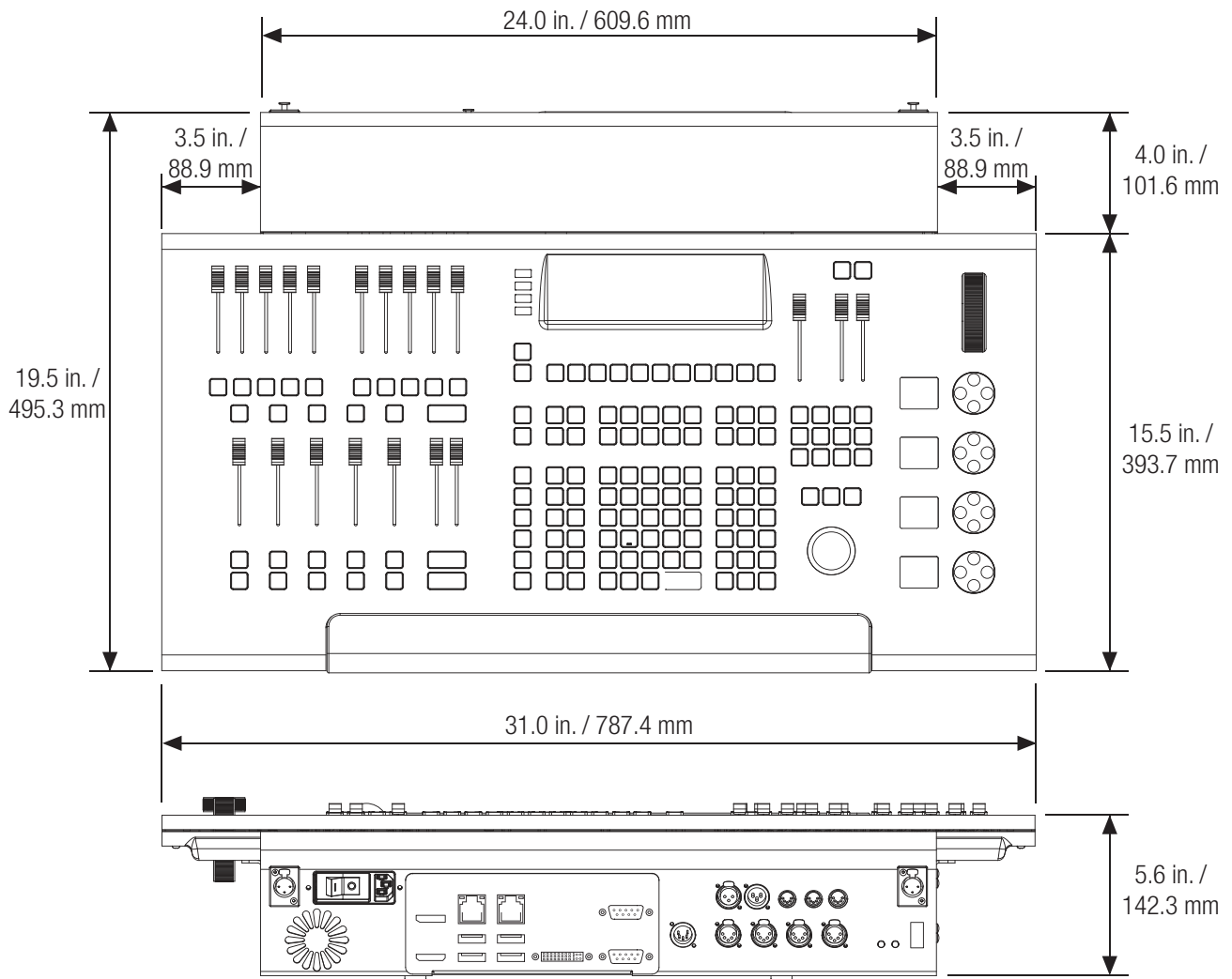

### Technical Specifications

#### Electrical

Supply Voltage: Universal power supply 100-240VAC  
 Approvals: cETLus, CE, C-Tick

#### Mechanical

Construction: High Density and Impact Resistant Aluminum and Plastics  
 Operating Temperature: 0° to 40°C ambient (32° to 104°F)  
 Humidity: 0% - 95% non-condensing  
 Storage Temperature: 0° to 35°C (32° to 95°F)  
 Weight: 37.0 lbs (16.8 kgs) - Console Only (no accessories)

#### Protocols / Connectivity

- Shownet
- E1.31 (Streaming ACN)
- Artnet
- DMX512
- KiNet (Philips Color Kinetics Control Protocol)
- Pathway
- RDM

#### Connections / Ports

- 4 DMX Out via 5-pin DMX
- 1 DMX In via 5-pin DMX
- 1 MIDI In / Out
- 1 SMPTE In / Out
- 1 VESA Display Port
- 1 HDMI Port
- 1 DVI Port
- 2 Network Ports – RJ45
- 1 Audio Line In/Out/Mic In – via 1/8" mini
- 2 COM ports
- 2 USB 3.0 (on rear panel)
- 7 USB 2.0 (2 on rear panel, 4 on front of console, and 1 in keyboard drawer)
- 2 3-pin XLR ports (12 Volt) for Console Lights (2 console lights are included with each console purchased)



### Ordering Information

#### Cat. No. Description

#### NEO Lighting Control Consoles

**91001** NEO Lighting Control Console (One Universe of DMX)

Includes: Console dust cover, universal voltage power supply, IEC Cables (1 each - US, Europe, Asia) Console Lights (2 each), and quick start guide. Monitor not included.

#### Peripheral Equipment - Cables

**95090** DMX512 Control Cable 25' (A5F to A5M)  
**96456** Ethernet cable 10' 10/100BaseT (RJ-45)  
**96459** Ethernet cable 25' 10/100BaseT (RJ-45)

#### Accessories

**91001-DC** Replacement Dust Cover  
**91002** One NEO Console Universe of DMX (512 Channels)\*  
 Note: \*Up to 100 can be ordered on one console.  
**91021** 21-inch Touch Screen Monitor (Multi-Touch)  
**66219** Additional / Replacement Console Light

### Philips Strand Lighting

**Dallas**  
 10911 Petal Street  
 Dallas, TX 75238  
 Tel: +1 (214) 647-7880  
 Fax: +1 (214) 647-8031

**Auckland**  
 19-21 Kawana Street  
 Northcote, Auckland 0627  
 New Zealand  
 Tel: + 64 9 481 0100  
 Fax: + 64 9 481 0101

[www.strandlighting.com](http://www.strandlighting.com)  
 © Philips Group 2014  
 All rights reserved.  
 The Company reserves the right to make any variation in design or construction to the equipment described. E&OE

**Asia**  
 Unit C, 14/F,  
 Roxy Industrial Centre  
 No. 41-49 Kwai Cheong Road  
 Kwai Chung, N.T., Hong Kong  
 Tel: + 852-2796-9786  
 Fax: + 852-2798-6545

**Europe**  
 European Service & Distribution Centre  
 Rondweg zuid 85  
 Winterswijk 7102 JD  
 the Netherlands  
 Tel: +31 (0) 543-542516

102615\_NA\_EUA