



High End Systems Ministar Automated Luminaire User Manual

Version 1.3.1

Part Number: 2540M1200-1.3.1 Rev: A

Released: 2024-01

To view a list of ETC trademarks and patents, go to etconnect.com/ip. All other trademarks, both marked and not marked, are the property of their respective owners.

You can find complete High End Systems terms and conditions and warranty information at etconnect.com/Support/Warranty.aspx.

For a complete list of all third-party licenses that are fully incorporated herein to the extent required by each third-party license terms and conditions, please visit etconnect.com/licenses.

ETC intends this document, whether printed or electronic, to be provided in its entirety.

Table of Contents

Introduction	1
Document Conventions	1
Help from Technical Services	2
Safety Considerations	3
General Operation and Use Guidelines	5
Fixture Overview	6
User Interface	7
Navigation Controls	7
Specifications	8
Environment	8
Power	8
Electrical	8
Input and Power Factor	8
Fixtures per Circuit	8
Connector Specifications	9
Install the Fixture	10
DMX Control	12
DMX Connector Pinout	12
Connect DMX Cables to Fixture	12
Terminate DMX	13
Set the DMX Start Address	13
DMX Channels	13

Configure the Fixture	14
Set Fixture Parameters	14
DMX Address	14
Set Menu	15
Test Menu	17
Info Menu	18
Preset Menu	19
Configure the Fixture Wirelessly	19
Replace a Gobo	20
Gobo Orientation	20
Replace a Gobo	21
Error Codes	25
Maintenance	27
Clean the Fixture	27
Update Fixture Software	27
Replace the Fuse	27
Compliance	28
FCC Compliance	28

Introduction

This manual provides important information for the safe installation, configuration, and maintenance of your High End Systems Ministar fixture. For your safety, read this entire manual prior to installing, operating, or servicing the fixture.

ETC recommends that you update your fixture with the latest version of software before you use the fixture. Software is available for free download from the ETC website:

etconnect.com/Products/Automated-Fixtures.

- See [View Software Version on page 19](#) to determine which version of software is currently installed on your fixture.
- See [Update Fixture Software on page 27](#) for instructions about updating your fixture.

Document Conventions

This document uses the following conventions to draw your attention to important information.



Note: Notes are helpful hints and information that is supplemental to the main text.



CAUTION: A Caution statement indicates situations where there may be unwanted consequences of an action, potential for data loss, or an equipment problem.



CAUTION: Hot Surfaces. This statement indicates that while operating, equipment surfaces may reach very high temperatures. Allow the fixture to cool before handling or servicing.



WARNING: A Warning statement indicates situations where damage may occur, people may be harmed, or there are serious or dangerous consequences of an action.



WARNING: RISK OF ELECTRIC SHOCK! This warning statement indicates situations where there is a risk of electric shock.

All ETC High End Systems documents are available for free download from our website: etconnect.com/Products/Automated-Fixtures.

Please email comments about this manual to: TechComm@etconnect.com.

Help from Technical Services

If you have questions that are not answered by this document, try the ETC support website at support.etconnect.com or the High End Systems product website at etconnect.com/Products/Automated-Fixtures. If none of these resources are sufficient, contact ETC Technical Services directly at one of the offices identified below. Emergency service is available from all offices outside of normal business hours.

When calling for help, take these steps first:

- Prepare a detailed description of the problem
- Go near the equipment for troubleshooting
- Find your notification number if you have called in previously

ETC, Inc.

Americas

Technical Services Department
3031 Pleasant View Road
Middleton, WI 53562
800-775-4382 (USA, toll-free)
+1-608 831-4116
service@etconnect.com

ETC GmbH

*Germany, Austria, Switzerland,
Eastern Europe, and Russia*

Technical Services Department
Ohmstrasse 3
83607 Holzkirchen, Germany
+49 (80 24) 47 00-0
techserv-germany@etconnect.com

ETC Austin

High End Systems Products

Technical Services Department
2105 Gracy Farms Lane
Austin, TX 78758 USA
800-890-8989 (USA, toll-free)
+1-512 836-2242
hesservice@etconnect.com

ETC France

France

Zone Urbaparc -
Bâtiment E
6 Boulevard de la Libération
Saint-Denis, 93200
+33 1 4243 3535
techservfrance@etconnect.com

ETC Ltd

Europe, Middle East, and Africa

Technical Services Department
26-28 Victoria Industrial Estate
Victoria Road,
London W3 6UU England
+44 (0)20 8896 1000
techservltd@etconnect.com

ETC Asia

Asia

Technical Services Department
Room 1801, 18/F
Tower 1, Phase 1 Enterprise Square
9 Sheung Yuet Road
Kowloon Bay, Kowloon, Hong Kong
+852 2799 1220
techserv-asia@etconnect.com

Safety Considerations

To ensure safe operation, follow the safety instructions and warning notes in the user manual.

- This fixture is intended for professional use only. Not for residential use. Read the entire manual before using this equipment.
 - Contact your authorized ETC dealer or Technical Services before performing any service in order to maintain warranty coverage.
-



WARNING: Note the following safety warnings before use:

- This equipment is designed for operation by qualified personnel only.
 - Do not stare at the operating lamp. May be harmful to the eyes.
 - Replace fuses with the specified type and rating only. See [page 27](#).
 - Ensure that the available voltage is within the stated range. See [page 8](#).
 - Do not use this fixture with a damaged power lead (cord set). If the lead is damaged, it must be replaced by a qualified technician with an equivalent type before use. Contact your local authorized dealer for replacement power leads.
 - Do not use this fixture if the lens is damaged. Damaged lenses must be replaced before use. Contact your local authorized dealer for a replacement.
 - Do not mount the fixture on or near flammable surfaces.
 - The fixture should be positioned so that prolonged staring into the fixture at a distance closer than 6.4 m (21 ft) is not expected.
 - Minimum distance from fixture head to combustible materials: 0.1 m (4 in).
 - Minimum distance to lighted objects: 2.0 m (6 ft 7 in).
-



AVERTISSEMENT : Pour votre sécurité, lisez les mises en garde et les avis suivants avant toute utilisation :

- Cet équipement est conçu pour être utilisé par un personnel qualifié uniquement.
 - Ne regardez pas la lampe en fonctionnement. Peut être nocif pour les yeux.
 - Remplacez les fusibles uniquement par le type et le calibre indiqués. Voir [page 27](#).
 - Veillez à ce que la tension disponible soit dans la plage indiquée. Voir [page 8](#).
 - N'utilisez pas ce projecteur avec un cordon d'alimentation endommagé (fils électriques). Si le cordon est endommagé, un technicien qualifié doit le remplacer par un cordon de type équivalent avant que l'appareil ne puisse être utilisé. Contactez votre distributeur agréé local pour obtenir des cordons d'alimentation de rechange.
 - N'utilisez pas cet appareil si la lentille est endommagée. Les lentilles endommagées doivent être remplacées avant l'utilisation. Contactez votre revendeur agréé local pour un remplacement.
 - Ne pas installer le projecteur sur ou à côté d'une surface inflammable.
 - L'appareil doit être positionné de manière à ce qu'un regard prolongé dans l'appareil à une distance inférieure à 6,4 m (21 pi) soit peu probable.
 - Distance minimum entre la tête du luminaire et les matériaux combustibles : 0.1 m (4 in).
 - Distance minimum avec les objets éclairés : 2.0 m (6 ft 7 in).
-

**WARNING: RISK OF ELECTRIC SHOCK!**

- Do not operate this device with the cover open.
- Disconnect the fixture from power and DMX and allow it to cool before performing any cleaning and maintenance.

AVERTISSEMENT : RISQUE DE CHOC ÉLECTRIQUE!

- N'utilisez pas cet appareil avec le couvercle ouvert.
- Débrancher la lampe de son alimentation et du DMX et la laisser refroidir avant d'effectuer un nettoyage ou un entretien.



RISK GROUP 2: CAUTION. *Possibly hazardous optical radiation emitted from this product. Do not stare at operating lamp. May be harmful to the eyes.*

GROUPE DE RISQUE 2 (RISQUE MODÉRÉ) : ATTENTION. *Rayonnement optique potentiellement dangereux émis par ce produit. Ne regardez pas la lampe en fonctionnement. Peut être nocif pour les yeux.*



CAUTION: Hot Surfaces. *Allow the device to cool completely before handling and servicing.*



ATTENTION : Surfaces chaudes. *Laissez le luminaire refroidir complètement avant de le manipuler et de procéder à son entretien.*



Note: *The light source in this luminaire is not user-replaceable, and must be replaced only by a qualified technician. Contact ETC Customer Support for assistance.*

Symbols used on the product label are defined below:

	The luminaire must be installed at least 2.0 m (6 ft 7 in) away from all lighted objects.	Le luminaire doit être installé à au moins 2,0 m (6 pi. 7 po.) de tout objet éclairé.
	General warning	Avertissement général
	Do not stare at the operating light source.	Ne pas regarder la source de lumière lorsqu'elle fonctionne.
	This product should not be discarded as unsorted waste but must be sent to separate collection facilities for recovery and recycling.	Ce produit ne doit pas être jeté avec les déchets ménagers mais doit être déposé dans une collecte de déchets électroniques ou dans un point de collecte.
t_a or T_a	Rated maximum ambient temperature	Température ambiante maximale recommandée
	Operate indoors only, not where this product would be exposed to the weather.	Ne fonctionne qu'à l'intérieur, pas là où ce produit serait exposé aux intempéries.

General Operation and Use Guidelines

- This fixture is only allowed to be operated with the maximum alternating current that is stated in the technical specifications label provided on the fixture.
- Lighting effects are not designed for permanent operation. Consistent operation breaks may extend the life of the fixture.
- When choosing the installation location, make sure the fixture will not be exposed to extreme heat, moisture, or dust.
- Do not point the lens toward the sun or other bright light source. Doing so could damage the fixture.
- If using the supplied brackets with quick-locking thumb screws to hang the fixture, ensure that the thumb screws have engaged a complete 90-degree positive latch.
- Operate the fixture only after having familiarized yourself with its functions. Do not permit persons who are not qualified and familiar with its functions to operate the fixture.
- Do not modify the fixture. Any modifications will void the warranty.
- This manual describes the proper installation and operation of this fixture. Using this fixture in any way other than the intended use may cause damage and void the warranty.
- When the fixture has been stored or transported in cold temperatures, allow it to warm to room temperature for a minimum of one hour before applying power. Applying power to a cold fixture may cause damage to the fixture and void the manufacturer warranty.
- Please use the original packaging if the fixture is to be transported. ETC will not be responsible for the fixture if packaging other than manufacturer provided packaging is used.

Fixture Overview

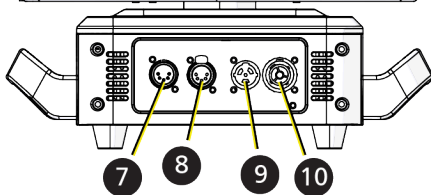
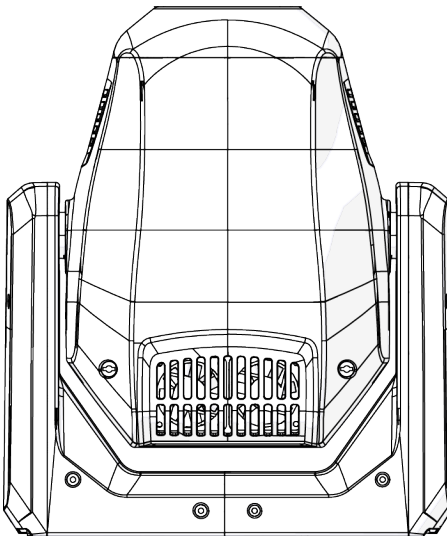
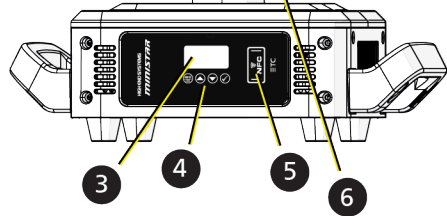
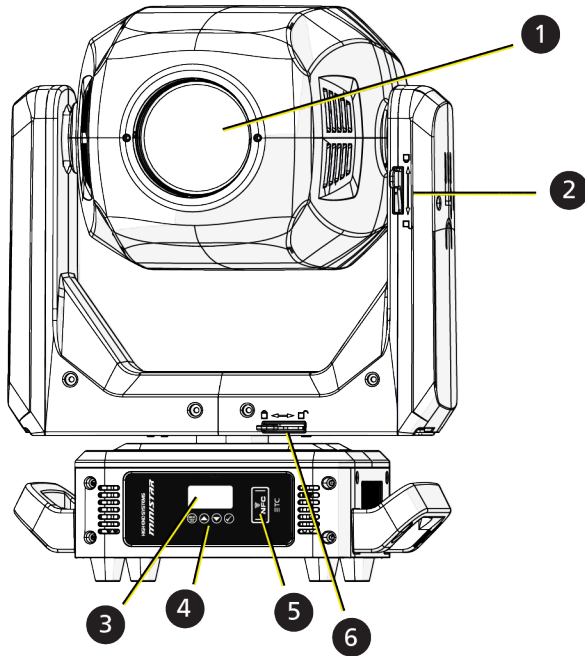

- 1. Lens
- 2. Tilt lock
- 3. Display
- 4. Navigation controls
- 5. NFC (Near Field Communication) tag
- 6. Pan lock
- 7. DMX In
- 8. DMX Thru
- 9. Power In
- 10. Power Out

User Interface

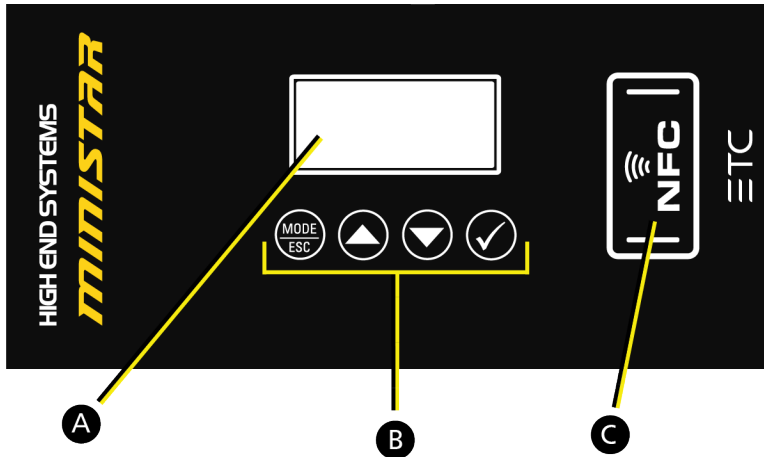

A	Display: Shows fixture configuration options in menu format. See Configure the Fixture on page 14 for details about the menu options.
B	Navigation controls: Use these buttons to navigate the main menu. See Navigation Controls below for details.
C	NFC Tag: Use the ETC Set Light app to wirelessly configure the fixture, with or without power applied to the fixture. See Configure the Fixture Wirelessly on page 19 .

Navigation Controls

Button	Function
	Access the main menu
	Navigate through menu options
	Select a menu item

1. Press [MODE/ESC] to access the main menu.
2. Browse the menu by pressing the up or down navigation buttons.
3. Press Enter to select a menu item.
4. Modify the selection by pressing the up or down navigation buttons according to the selection.
5. Press Enter to confirm a modified selection.
6. To exit the menu, press [MODE/ESC].

Specifications

For complete technical specifications, see the technical datasheet:
etcconnect.com/Ministar/Documentation.

Environment

- Ambient operating temperature range: -10°C to 40°C (14°F to 104°F).
- Relative humidity: 0%–90%, non-condensing.
- Storage temperature: -20°C to 60°C (-4°F to 140°F).
- Indoor use only.
- Dry locations only, IP20 rated.

Power



WARNING: Connect the fixture to a non-dimmable power source in order to avoid damage to the fixture's internal power supply and other electrical components. Using a dimmable power source can damage the fixture and will void the warranty.

Electrical

- 100–240 VAC at 50/60 Hz
- Listed maximum wattage: 450 W

Input and Power Factor

The values listed below were measured with LEDs at full and all motors functioning.

VAC	Amps	Hz	Watts	VA	PF
100	4.8	50	480	509	0.99
120	4.0	60	480	497	0.99
200	2.5	50	480	484	0.98
208	2.4	60	480	489	0.97
220	2.3	50	479	491	0.97
230	2.2	50	479	495	0.97
240	2.1	60	473	492	0.95



CAUTION: Using this fixture below 100 V on a 15 A breaker may cause the breaker to trip. Ensure that the circuit can handle the fixture's maximum potential draw before you connect it.

Fixtures per Circuit

- 3 fixtures via the 15 A power thru connectors
- 4 fixtures via an ETC R20 or similar breaker module

Consult the upstream breaker trip curves when using something other than an ETC R20 or similar breaker module.

Connector Specifications



WARNING: Risk of Shock and Fire. Assemble a grounding-type attachment plug with integral cord grip that is within the voltage and amperage rating of this luminaire.

AVERTISSEMENT : Risque de choc et d'incendie. Assurez-vous d'utiliser une prise de mise à la terre avec décharge de traction intégrée qui respecte la tension et l'ampérage de ce luminaire.

A power input cable with powerCON® TRUE1® TOP input to bare ends is provided. The power input cable is rated for maximum 20 A (120 VAC/60 Hz) and 16 A (240 VAC/50 Hz). Install a suitable connector to meet the installation requirements. See the following wire color code chart:

Wire Color Code (EU)	Wire Color Code (US Standard)	Connection type	Terminal
Green/Yellow	Green	Earth/Ground	\perp
Blue	White	Neutral	N
Brown	Black	Line (Live)	L

Install the Fixture

Overhead rigging must be performed by qualified personnel. Follow all local and national codes and recommended practices.



WARNING:

- The installation location must support a minimum point load of 10 times the weight of the fixture. Fixture weight is 16.2 kg (35.7 lb).
 - The installation must always be secured with a secondary safety attachment. An appropriate safety cable is supplied.
 - Safety cable attachment must be rated by a safety factor of 10.
 - A supportive and stable surface must be used when fixtures are placed on their feet.
 - Never stand directly below the installed fixture when mounting, removing, or servicing the fixture.
 - All safety and technical aspects of fixture installation must be approved by qualified personnel before operation.
 - The installation must be regularly inspected by qualified personnel.
-



AVERTISSEMENT :

- L'emplacement d'installation doit supporter une charge concentrée minimale de 10 fois le poids de l'appareil. Le poids du projecteur est de 16.2 kg.
 - L'installation doit toujours être sécurisée par une fixation de sécurité auxiliaire. Un câble de sécurité approprié est fourni.
 - La fixation du câble de sécurité doit être classée avec un facteur de sécurité de 10.
 - Une surface d'appui stable doit être utilisée quand les projecteurs sont placés sur pieds.
 - Ne vous placez jamais directement sous le projecteur lors du montage, du démontage ou de son entretien.
 - Tous les aspects techniques et de sécurité de l'installation du projecteur doivent être approuvés par un personnel qualifié avant qu'il ne soit utilisé.
 - L'installation doit être régulièrement inspectée par du personnel qualifié.
-

You can install the fixture in any of the orientations shown below.

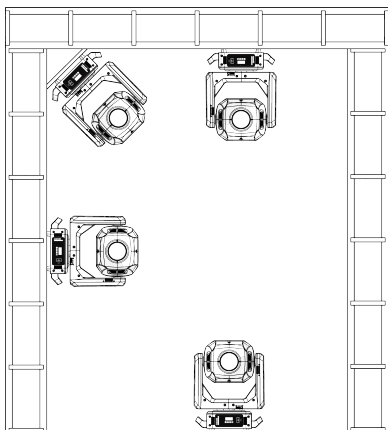

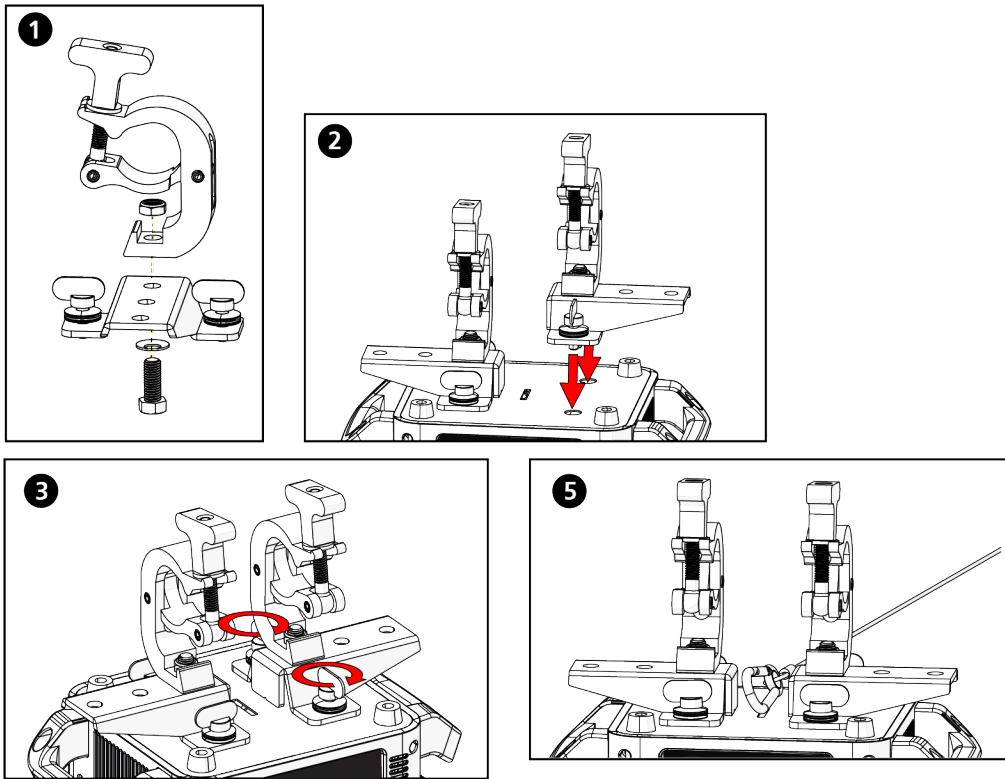

1. Assemble the clamp (provided by others) to the bracket that was provided with the fixture and secure together using appropriately sized hardware (not provided). You can use any of the holes in the three-hole bracket depending on how you want to align the fixture in the truss.
2. Align the assembled bracket and quick-lock fasteners into the respective holes on the bottom of the fixture upper enclosure.
3. Tighten each of the quick-lock fasteners fully, turning clockwise. You will hear and feel a click when the fastener is fully secured.
4. Attach the fixture to the installation location using the clamp manufacturer's instructions for a secure fit. When using an Omega clamp, close the safety and fully tighten the clamp wing nut until secure.
5. Secure the safety cable to the trussing system or some other safe installation point. Follow local codes and recommended safety standards for securing the fixture to the installation location.
6. Unlock the pan and tilt locks.
7. Apply power to the fixture.
8. Inspect the installation prior to lifting the fixture overhead.

DMX Control

The Ministar fixture operates on standard DMX-512 control bus, controlled by a DMX console. The fixture requires 39 channels of DMX-512.

Attach the fixture to the control bus using a two-core, shielded cable with a 5-pin XLR connector (Belden 9729 is preferred).

The fixture includes two 5-pin XLR connectors, one for DMX Input and one for DMX Thru (for use when daisy-chaining fixtures on the DMX control bus).

DMX Connector Pinout

Use the following standard pinout when preparing DMX cable with 5-pin XLR connectors. ETC recommends using Belden 9729 or equivalent cable. (See the ETC cable cross database for equivalent alternatives: etcconnect.com/Support/Cable-Cross-Database.aspx.) The second data pair in the recommended cable type is not used, but is reserved for future service.

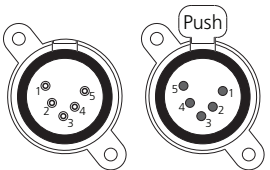
DMX-512 Pinout for Five-Pin XLR	Pin	Use
	1	Common (shield)
	2	Data -
	3	Data +
	4	Not connected
	5	Not connected

Connect DMX Cables to Fixture

The following instructions are guidelines for connecting DMX to your fixture. Your installation may vary.

1. Connect a DMX data cable to the DMX control source and the DMX In XLR receptacle on the first fixture in the DMX data run.
2. Link the remaining fixtures in the data run by connecting a DMX data cable from the DMX Thru connector on a fixture to the DMX In connector on the next fixture in the data run.



Note: A maximum of 32 DMX devices may be connected in any one DMX data run when installed in a daisy-chain fashion.

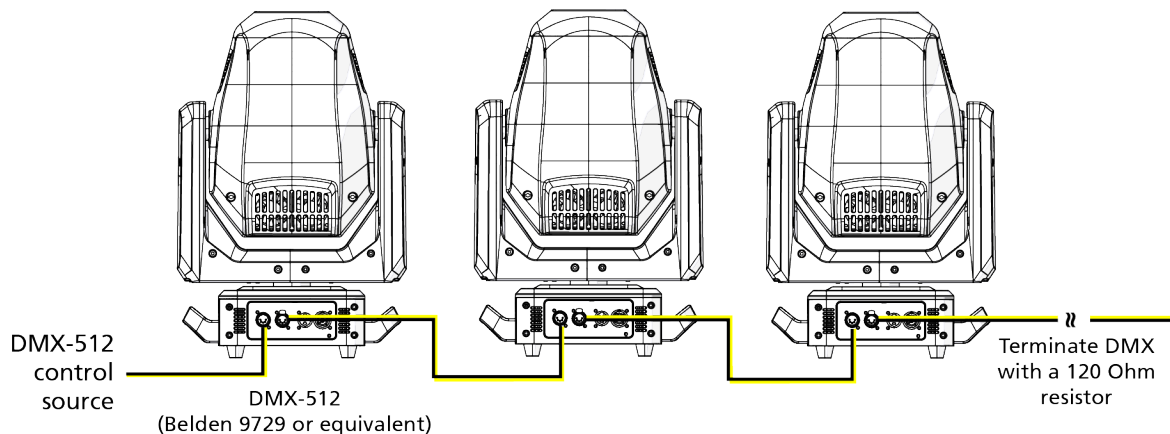

Terminate DMX

Use a DMX terminator or install a resistor on the last fixture of the DMX control run to prevent corruption (data reflection) of the digital control signal by electrical noise.

A DMX terminator is an XLR plug with a 120 Ω resistor connected between pins 2 and 3 that can be installed into the DMX output receptacle of the last fixture in the DMX control run. Contact your authorized dealer or ETC for ordering information (etcconnect.com/contactETC), or purchase an XLR DMX terminator from the ETC Online Shop (shop.etcconnect.com).

Set the DMX Start Address

Give each fixture a unique DMX starting address so that the correct fixture responds to the control signals. This DMX start address is the channel number from which the fixture starts to “listen” to the digital control information sent out from the control source.

Modify the DMX start address on the user interface, which is located on the upper enclosure. See [DMX Address on page 14](#).



Example: *The Ministar requires 39 channels of control. If you set the DMX starting address of the first fixture to 1, you could set the second fixture to 32 (31+1), the third to 63 (31+32), and so on.*

DMX Channels

The current DMX channel map for the Ministar can be found on the ETC website: etcconnect.com/Ministar/Documentation.

Configure the Fixture

You can configure the Ministar fixture through the onboard user interface (see [Set Fixture Parameters below](#)), or use the ETC Set Light App to wirelessly configure the fixture (see [Configure the Fixture Wirelessly on page 19](#)).

Set Fixture Parameters

This section provides instructions to configure the Ministar. See [Fixture Overview on page 6](#) for information about the user interface and navigation controls.

DMX Address

Navigate: Main Menu → Address

Set the DMX address for the fixture. The default value is 001.

Set Menu

Set the Status Options

Navigate: Main Menu → Set → Status

Parameter	Value	Description
Data Loss	Hold Last	Control mode when DMX is absent. The default value is Hold Last.
	LED Off	
	Auto	
Pan Inv	ON	Reverse the pan movement of the fixture. The default value is OFF.
	OFF	
Tilt Inv	ON	Reverse the tilt movement of the fixture. The default value is OFF.
	OFF	
Pan Degrees	540	Change the pan rotation of the fixture from the default setting of 540 degrees to 630 degrees.
	630	
Encoders	ON	Turn on or off the encoder feedback for pan and tilt movement. You may want to turn off encoders when working on a fixture so that you can move pan and tilt without the fixture automatically moving back to position.
	OFF	
P/T Speed	1–4	Set the speed (scan mode) of pan and tilt movement. The default value is 1. Use this parameter to make fine adjustments to pan and tilt movement in order to correct for mis-stepping when the fixture is installed on its side (side-hung, or "Outrig").
Hibernat Time	OFF	Hibernation mode forces the LEDs and stepper motors to power off when the fixture loses DMX control signal for a set period of time. The default time setting is 15 minutes.
	1–99 minutes	
Dimming Mode	16 kHz	Set the dimming curve and pulse width modulation (PWM) frequency. The default value is 16 kHz. 16 kHz is quieter than 2.4 kHz and creates a beam that does not flicker when shown on camera. 2.4 kHz prioritizes flawless, stepless dimming.
	2.4 kHz	
P/T Home Mode	Standard	Set the order in which pan and tilt homing is performed. <ul style="list-style-type: none">• Standard: the pan and tilt home procedures run simultaneously.• Tilt First: the tilt home procedure runs to completion, then the pan home procedure begins.• Pan First: the pan home procedure runs to completion, then the tilt home procedure begins.
	Tilt First	
	Pan First	

Access Service Settings

Navigate: Main Menu → Set → Service Settings

Parameter	Value	Description
Service PIN	Service PIN XXX	You must enter the Service PIN in order to access the other Service Setting parameters. The default Service PIN is 050.
RDM UID	Manufacturer ID and a randomly generated number	This password-protected menu item lets you modify the RDM UID. You must enter the Service PIN to access this menu item. Note: Remote Device Management (RDM) requires that all RDM devices have a unique identifier (UID). Modifying this setting can break the RDM capability of this fixture. Duplicate RDM UIDs on the same DMX control run will result in a data collision, causing a communication failure. Ensure that all fixtures have a unique RDM UID if RDM functionality is to be used. If DMX splitters are used and RDM control is to be used, these splitters must support RDM.
Clr Err Info	ON	This password-protected menu item lets you clear error messages after you have fixed the errors. You must enter the Service PIN to access this menu item. Set this parameter to ON in order to clear the error messages. The default setting is OFF.
	OFF	
NFC Lock	ON	When set to OFF , the NFC tag is available to wirelessly configure the fixture. See Configure the Fixture Wirelessly on page 19 . The default setting is OFF .
	OFF	

Set the Fan Mode

Navigate: Main Menu → Set → Fan Mode

Select the fan mode for the fixture:

- Standard
- Studio (reduces fan noise, but decreases fixture output by ~20%)

Set Display Settings

Navigate: Main Menu → Set → Display

Parameter	Value	Description
Shutoff Time	02–60 minutes	Enter the amount of time the fixture waits after the last user interface button press until the display goes to sleep. The default value is 5 minutes.
Key Lock	ON	Lock the user interface. The default value is OFF. To unlock the user interface navigation buttons, press and hold the [MODE/ESC] button for three seconds.
	OFF	

Set the Temperature Scale

Navigate: Main Menu → Set → Temp C/F

Select the temperature scale for the fixture:

- Celsius (default value)
- Fahrenheit

Reset Fixture to Factory Default Settings

Navigate: Main Menu → Set → Reset Defaults

Select ON to reset the fixture to the factory default settings.

Test Menu

Reset (Home) the Mechanical Positions on the Fixture

Navigate: Main Menu → Test → Home

Reset ("home") all features on the fixture, including, pan, tilt, colors, gobos, etc.

Test the Fixture

Navigate: Main Menu → Test → Self Test

Run a self-test program on the fixture. When you run the test, the display indicates "Running" and the fixture automatically runs a self-test procedure, testing each of the functions. Press the [MODE/ESC] button to end the self-test and return the display to the previous menu.

Test an Individual Channel

Navigate: Main Menu → Test → Test Channel

Run a self-test program on individual channels. The default value is Control. Select a different channel to run a self-test on that channel.

Manually Set an Individual Channel

Navigate: Main Menu → Test → Manual Control

Select an individual channel on the fixture and manually set the channel value. While in Manual Control mode, all effects are canceled, the shutter opens, and the dimmer intensity is set to 100%.

Re-Calibrate an Individual Feature

Navigate: Main Menu → Test → Calibrat

This menu is passcode protected and reserved for authorized technician use only. Contact ETC Technical Support for assistance.

Once you have accessed the Calibration menu, select an individual feature on the fixture and manually calibrate it to a new "home" setting.



Note: *Changes you make to the fixture settings in the Calibration menu are not changed if you reset the fixture to the factory default settings. The Calibration settings are saved until they are changed in the Calibration menu.*

Info Menu

Set the Time Information

Navigate: Main Menu → Info → Time

Parameter	Value	Description
Curr Hrs	XXXX (Hours)	Running time of the fixture from the last time that the fixture was powered on, shown in hours (h). The counter resets after the fixture is turned off.
Fixt Hrs	XXXX (Hours)	Total running time of the fixture, shown in hours (h).
Last Run Hrs	XXXX (Hours)	Running time of the fixture from the last time that the run time value was reset, shown in hours (h).
LED Hrs	XXXX (Hours)	Total running time of the fixture LEDs, shown in hours (h).
Last Run Password	Last Run Password	You must enter the Last Run password in order to access the Clr Last Run Hrs menu item. The default password is 038.
Clr Last Run Hrs	ON	This password-protected menu item resets the Last Run Hrs value. You must enter the Last Run password to access this menu item. Select ON to clear the value for the Last Run Hrs parameter.
	OFF	
LED Hrs Password	LED Hrs Password	You must enter the LED Hrs password in order to access the Clear LED Hrs menu item. The default password is 038.
Clear LED Hrs	ON	This password-protected menu item resets the LED Hrs value. You must enter the LED Hrs password to access this menu item. Select ON to clear the value for the LED Hrs parameter.
	OFF	

View Fixture Errors

Navigate: Main Menu → Info → Err History

Displays any current fixture errors. See [Error Codes on page 25](#) for information about the errors.

View DMX Values for Channels

Navigate: Main Menu → Info → DMX Values

View the DMX value of each of the fixture's channels (parameters of the fixture). Scroll to the parameter that you want to view (Pan, Tilt, etc.) and view the value. The DMX value that you view is the DMX value that displays on the main window of the UI until you select a different DMX value to view.

View Fixture Head Temperature

Navigate: Main Menu → Info → Head Temp

Displays the current fixture temperature as read from the fixture head (near the CMY filter).

View Power Supply Temperature

Navigate: Main Menu → Info → Base Temp

Displays the current temperature as read from the power supply in the fixture base, which can help you to determine if the power supply is overheating.

View Fan Speeds

Navigate: Main Menu → Info → Fan Speed

Displays the speeds of the fixture's fans (in RPM).

View Software Version

Navigate: Main Menu → Info → Software Version

Displays the software version installed on the fixture.

Preset Menu

Navigate: Main Menu → Preset

Presets are built by combining scenes into programs and then assigning the programs to Program Partitions for playback. For information about the **Preset** menu, access the *High End Systems Preset Menu Guide* from the ETC support website: support.etcconnect.com.

Configure the Fixture Wirelessly



Note: *The **NFC Lock** option in the **Service** menu must be set to **Off** in order to configure the fixture wirelessly. See [Access Service Settings on page 16](#).*

Download the ETC Set Light app to a smartphone with NFC functionality, use the app to set fixture parameters, and then tap the smartphone to the NFC tag on the fixture to configure it wirelessly—even when the fixture is not powered on.

Visit etcconnect.com/Apps or scan the code for more information about the Set Light app.



Set Light

Replace a Gobo



CAUTION: RISK OF ELECTRIC SHOCK! Disconnect power before servicing.

ATTENTION : RISQUE DE CHOC ÉLECTRIQUE! Couper l'alimentation avant l'entretien.

For detailed gobo specifications, orientation, and size requirements, refer to the *Ministar Replacement Gobo Reference Guide* at etconnect.com/Ministar/Documentation.

Gobo Orientation

Before installing a new gobo, identify the reflective/mirrored side of the gobo to ensure the correct orientation of the new gobo in the gobo wheel.

The reflective/mirrored side of the gobo must face toward the LED engine when the gobo carrier is installed in the gobo wheel.

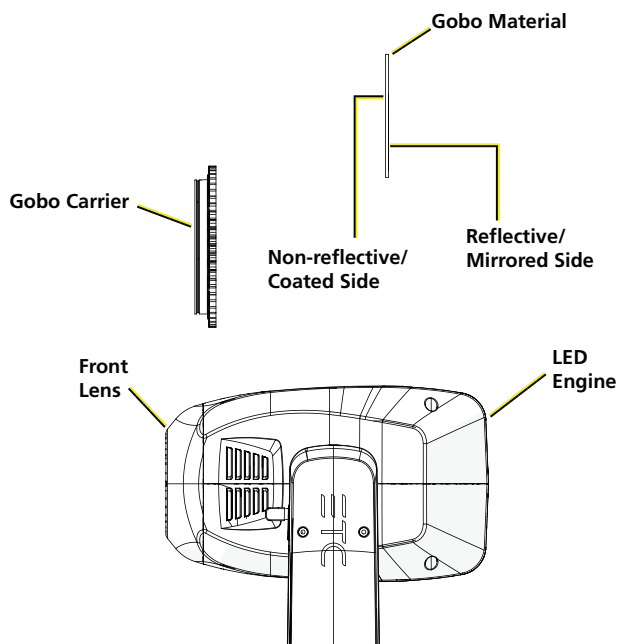

Replace a Gobo



Note: ETC recommends that you wear clean cotton gloves when changing gobos to protect the gobos from dirt and fingerprints.

Parts and tools required:

- #2 Phillips screwdriver
- Replacement gobo
- Precision flatblade screwdriver

1. Disconnect power to the fixture and allow it to cool completely before continuing.
2. Remove the head cover. You only need to remove the head cover that is on the top of the fixture when the front lens is facing away from you and the tilt lock is to the right of the fixture head.
 - a. Using a #2 Phillips screwdriver, loosen the captured Phillips screws that secure the cover to the fixture.
 - b. Lift the cover, and then detach the safety lanyard from the fixture to completely remove the cover.

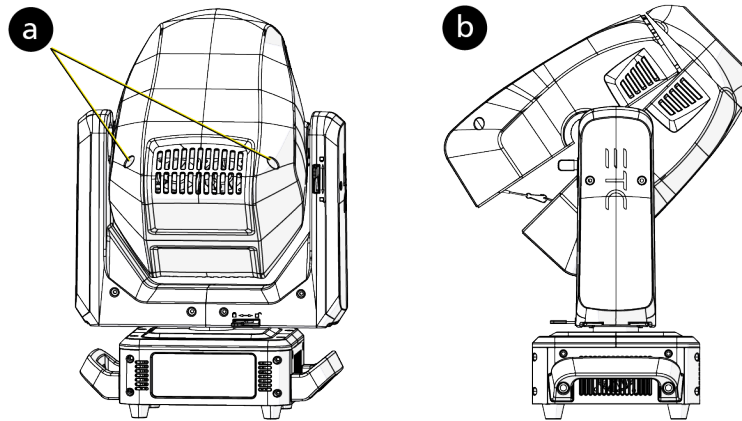

The gobo wheel is located in the effects module, which is located near the bottom of the fixture head above the LED engine.

3. Locate the gobo you want to remove.
4. Remove the gobo carrier from the gobo wheel.
 - a. Using a precision flatblade screwdriver or a finger nail, push down on the edge of the gobo carrier to move the carrier out of its slot in the gobo wheel.
 - b. Grip the edge of the gobo carrier and pull the carrier out of the gobo wheel.

5. Remove the gobo from the gobo carrier.
 - a. Use a precision flatblade screwdriver to carefully pry the spring out of the gobo carrier.
 - b. Remove the gobo from the gobo carrier.

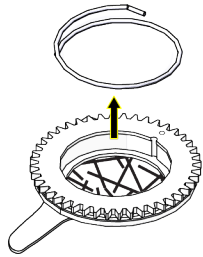

6. Insert the new gobo into the gobo carrier.
 - a. Verify that the reflective side of the gobo is facing up. (See [Gobo Orientation on page 20](#) for details.)
 - b. Align the alignment tab on the gobo with the notch in the gobo carrier, and insert the gobo into the carrier.

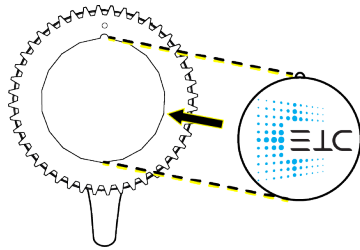

7. Carefully insert the spring into the gobo carrier to secure the gobo.

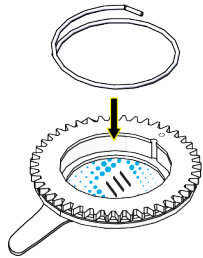

8. Each gobo carrier has a small index spot located adjacent to the notch in the gobo carrier (#3 in the following graphic). To ensure proper rotation of the gobos with respect to each other, the index spot on each gobo carrier in the gobo wheel must be aligned with the sun gear (central hub) before you install the new gobo.

Rotate the sun gear until each the index spot on each gobo carrier is aligned with its corresponding alignment key on the sun gear.

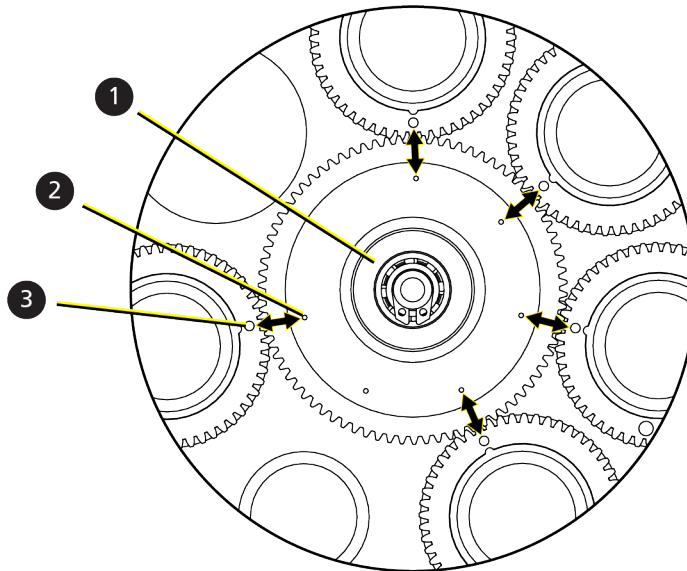

Item	Description
1	Sun gear
2	Alignment key
3	Index spot

In the example above the gobo in gobo position 2 is being replaced, so that gobo carrier is not shown.

9. For the new gobo you are installing, rotate the sun gear on the gobo carrier so that the index spot is centered on the fork of the gobo carrier.

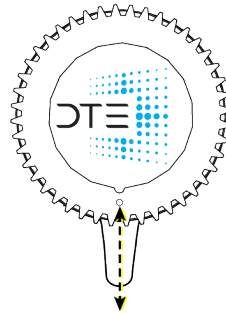

10. Insert the gobo carrier into the gobo wheel.
 - a. Locate the slot in which you want to install the gobo carrier.
 - b. Push the gobo carrier into its slot until the gobo carrier is firmly seated in the gobo wheel making sure that the index spot on the gobo carrier is aligned with the sun gear as shown in step 8.

11. Reinstall the head cover.

- a. Align the head cover with the fixture and reattach the safety lanyard to the fixture.
- b. Angle the cover under the front housing.
- c. Slide the back of the cover down and align its edges with the edges of the other cover.
- d. Secure the cover in place by tightening the captured Phillips screws.

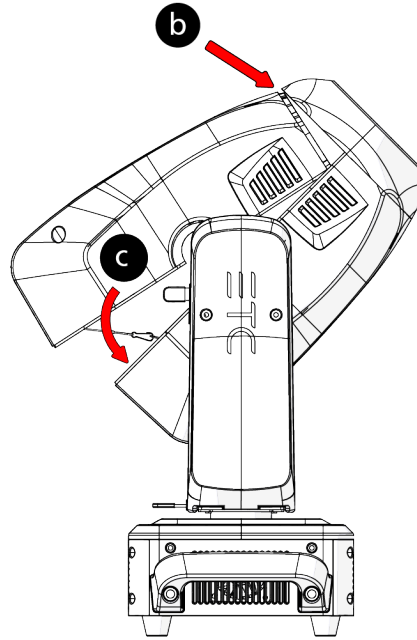

Error Codes

When you apply power to the fixture, it runs a calibration (homing) sequence and displays any errors that it detects.



Example: *When the display shows "Error channel: Pan Coarse", it means there is an error in channel 1. When multiple errors are present they will cycle on the display twice, and then the fixture will reset (restart). Any errors that remain after two reset cycles are not correctable by reset alone and will require service. These errors are stored in the fixture error history until the errors are cleared. Please contact Technical Services for assistance.*

Color 1

This message displays after the reset of the fixture if any of the following conditions exist:

- the fixture head's magnetic-indexing circuit malfunctions (optical or magnetic sensor failure)
- the stepper motor is defective or the related IC driver on the main PCB has failed
- Color wheel 1 is not located in the default position after reset.

Color 2

This message displays after the reset of the fixture if any of the following conditions exist:

- the fixture head's magnetic-indexing circuit malfunctions (optical or magnetic sensor failure)
- the stepper motor is defective or the related IC driver on the main PCB has failed
- Color wheel 2 is not located in the default position after reset.

Focus

This message displays after the reset of the fixture if any of the following conditions exist:

- the magnetic-indexing circuit malfunctions (optical or magnetic sensor failure)
- the stepper motor is defective or the related IC driver on the main PCB has failed
- the Focus wheel is not located in the default position after the reset

Frost 1

This message displays after the reset of the fixture if any of the following conditions exist:

- the magnetic-indexing circuit malfunctions (optical or magnetic sensor failure)
- the stepper motor is defective or the related IC driver on the main PCB has failed
- Frost wheel 1 is not located in the default position after the reset

Gobo 1

This message displays after the reset of the fixture if any of the following conditions exist:

- the magnetic-indexing circuit malfunctions (optical or magnetic sensor failure)
- the stepper motor is defective or the related IC driver on the main PCB has failed
- Gobo Wheel 1 is not located in the default position after the reset

Gobo Rot 1

This message displays after the reset of the fixture if any of the following conditions exist:

- the magnetic-indexing circuit malfunctions (optical or magnetic sensor failure)
- the stepper motor is defective or the related IC driver on the main PCB has failed
- Gobo Rotating Wheel 1 is not located in the default position after the reset

Pan

This message displays after the reset of the fixture if any of the following conditions exist:

- the yoke's magnetic-indexing circuit malfunctions (optical or magnetic sensor failure)
- the stepper motor is defective or the related IC driver on the main PCB has failed
- the Pan movement is not located in the default position after the reset

Prism 1

This message displays after the reset of the fixture if any of the following conditions exist:

- the fixture head magnetic-indexing circuit malfunctions (optical or magnetic sensor failure)
- the stepper motor is defective or the related IC driver on the main PCB has failed
- Prism wheel 1 is not located in the default position after the reset

Prism_Rot 1

This message displays after the reset of the fixture if any of the following conditions exist:

- the fixture head magnetic-indexing circuit malfunctions (optical or magnetic sensor failure)
- the stepper motor is defective or the related IC driver on the main PCB has failed
- Prism rotating wheel 1 is not located in the default position after the reset

Tilt

This message displays after the reset of the fixture if any of the following conditions exist:

- the fixture head magnetic-indexing circuit malfunctions (optical or magnetic sensor failure)
- the stepper motor is defective or the related IC driver on the main PCB has failed
- the Tilt movement is not located in the default position after the reset

Zoom

This message displays after the reset of the fixture if any of the following conditions exist:

- the magnetic-indexing circuit malfunctions (optical or magnetic sensor failure)
- the stepper motor is defective or the related IC driver on the main PCB has failed
- the Zoom wheel is not located in the default position after the reset

Maintenance



CAUTION: RISK OF ELECTRIC SHOCK! Disconnect power before servicing.

ATTENTION : RISQUE DE CHOC ÉLECTRIQUE! Couper l'alimentation avant l'entretien.

To ensure that the fixture remains in good working condition and does not fail prematurely, ETC recommends that you perform regular maintenance on the fixture.

Keep the following in mind during regular service and inspection:

- All screws for installing the fixture or parts of the fixture must be tightly connected and must not be corroded.
- There must not be any deformations to the housing, lenses, rigging, and installation points (ceiling, suspension, trussing).
- Moving parts must not show any signs of wear and must move smoothly without issue.
- The power supply cables must not show any damage, material fatigue, or sediment.
- If spare parts are required, order only genuine parts from ETC or your authorized ETC dealer.

Clean the Fixture

1. Clean the inside and outside of the lens regularly using a damp, lint-free cloth to avoid loss of output due to accumulation of dust/dirt on the lens. Never use alcohol or solvents.
 2. Clean the fans regularly to ensure maximum airflow and efficient cooling. This will ensure that the light source operates in the best possible condition.
-



Note: *If you use compressed air to clean the fans, hold the fan blades in place while cleaning them. Letting the fans spin while using compressed air could damage the fans.*

Update Fixture Software

When Ministar fixtures are connected to data, you can update software directly using UpdaterAtor. For information about UpdaterAtor, see the *UpdaterAtor Software Quick Guide* and the *UpdaterAtor Software Release Note*, which you can download from etconnect.com/Products/Networking/System-Configuration/Software/UpdaterAtor.aspx.

You can also update software using an uploader tool. Contact ETC or your ETC distributor to purchase an uploader tool. Software update instructions using the uploader tool are available on the ETC website: etconnect.com/WorkArea/DownloadAsset.aspx?id=10737503589.

Replace the Fuse

The fuse in this fixture is not user-replaceable. Contact ETC Technical Services for assistance. See [Help from Technical Services on page 2](#) for contact information.

Compliance

For current and complete compliance information, view the product datasheet at etcconnect.com/Products/Automated-Fixtures. For complete product documentation, including compliance documentation, visit etcconnect.com/products.

FCC Compliance

Ministar

(For any FCC matters):

Electronic Theatre Controls, Inc.
3031 Pleasant View Road
Middleton, WI 53562
+1 (608) 831-4116
etcconnect.com

This device complies with Part 15 of the FCC Rules. Operation is subject to the following two conditions: (1) this device may not cause harmful interference, and (2) this device must accept any interference received; including interference that may cause undesired operation. Visit etcconnect.com/products for current and complete compliance information including FCC compliance.



Note: *This equipment has been tested and found to comply with the limits for a Class A digital device, pursuant to Part 15 of the FCC rules. These limits are designed to provide reasonable protection against harmful interference when the equipment is operated in a commercial environment. This equipment generates, uses, and can radiate radio frequency energy and, if not installed and used in accordance with the instructions, may cause harmful interference to radio communications. Any modifications or changes to this product not expressly approved by Electronic Theatre Controls, Inc. could void the user's authority to operate the product. Operation of this equipment in a residential area is likely to cause harmful interference, in which case the user will be required to correct the interference at their own expense.*



Corporate Headquarters ■ Middleton, WI, USA | +1 608 831 4116
Global Offices ■ London, UK | Rome, IT | Holzkirchen, DE | Paris, FR | Hong Kong | Dubai, UAE | Singapore
New York, NY | Orlando, FL | Los Angeles, CA | Austin, TX | © 2024 Electronic Theatre Controls, Inc.
Web etconnect.com | **Support** support.etconnect.com | **Contact** etconnect.com/contactETC
Trademark and patent info: etconnect.com/ip | Third-party license agreement info: etconnect.com/licenses
Product information and specifications subject to change. ETC intends this document to be provided in its entirety.
2540M1200-1.3.1 Rev A Released 2024-01