

4

3

2

1

All Dimension in [Inch]
Metric

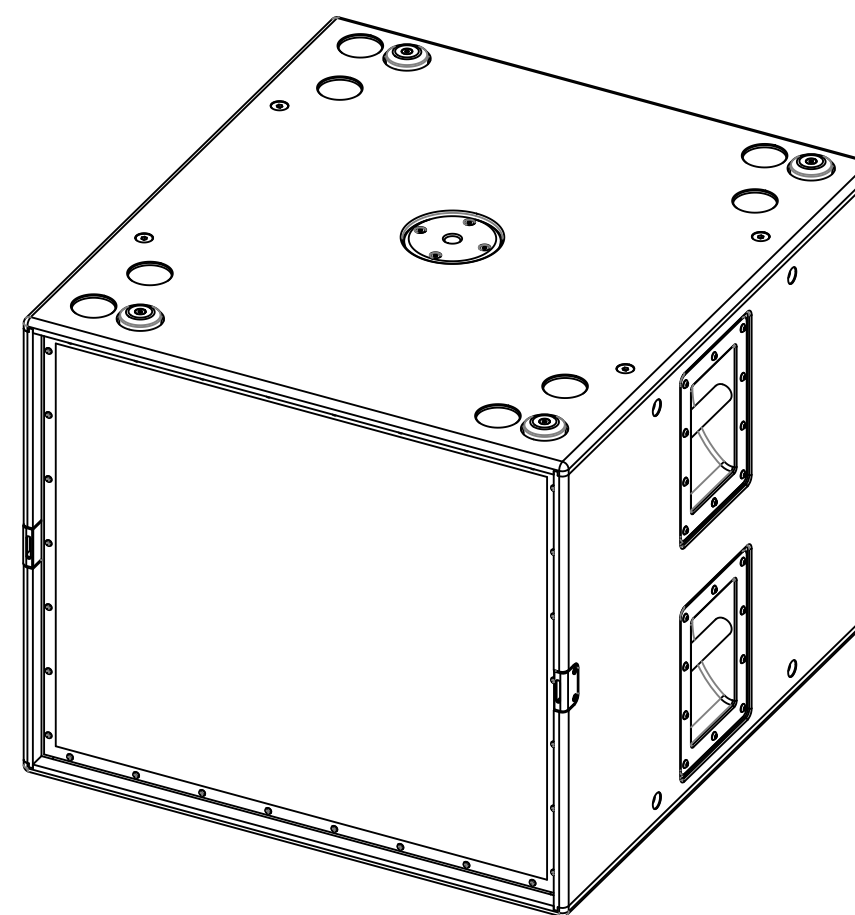
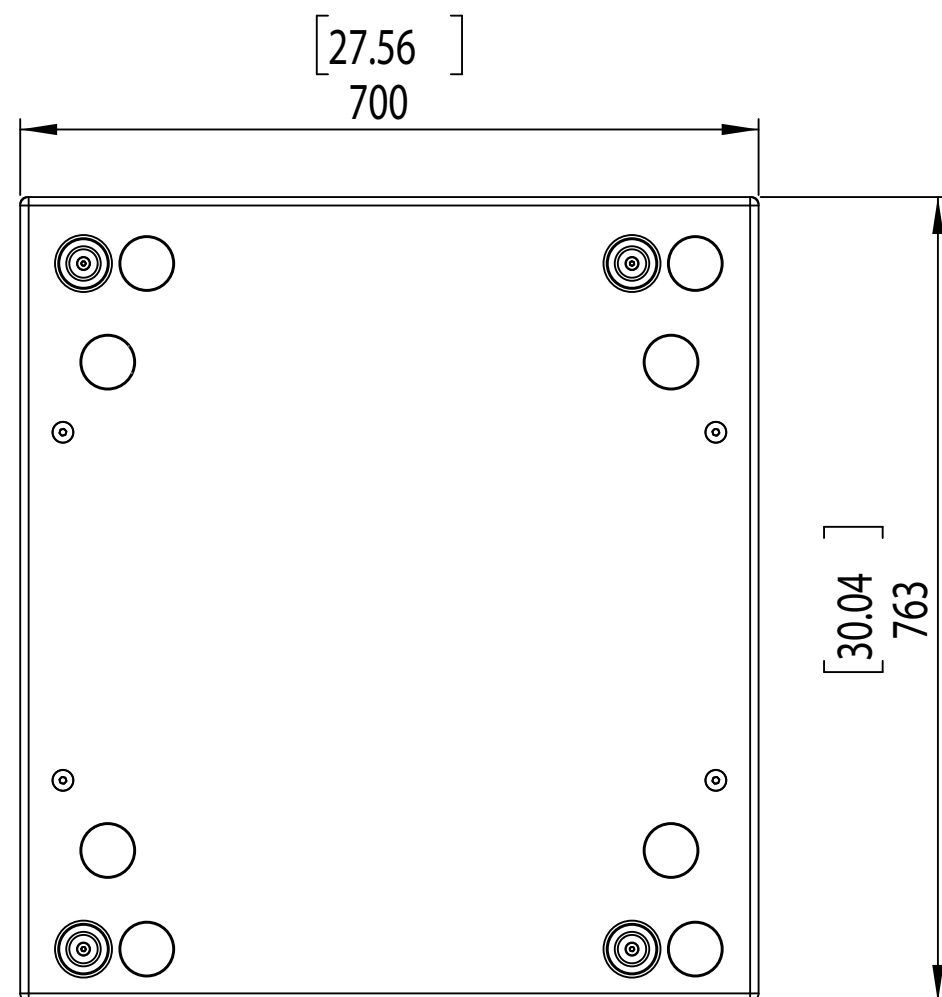
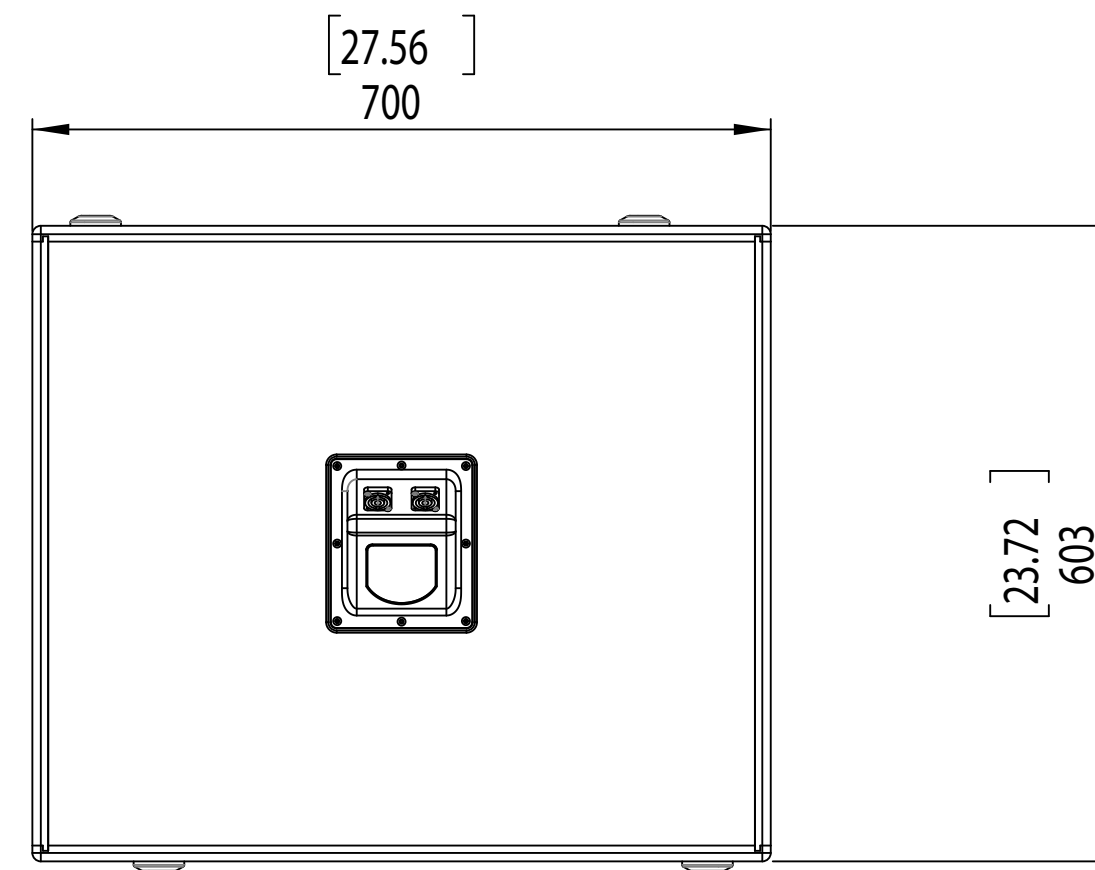
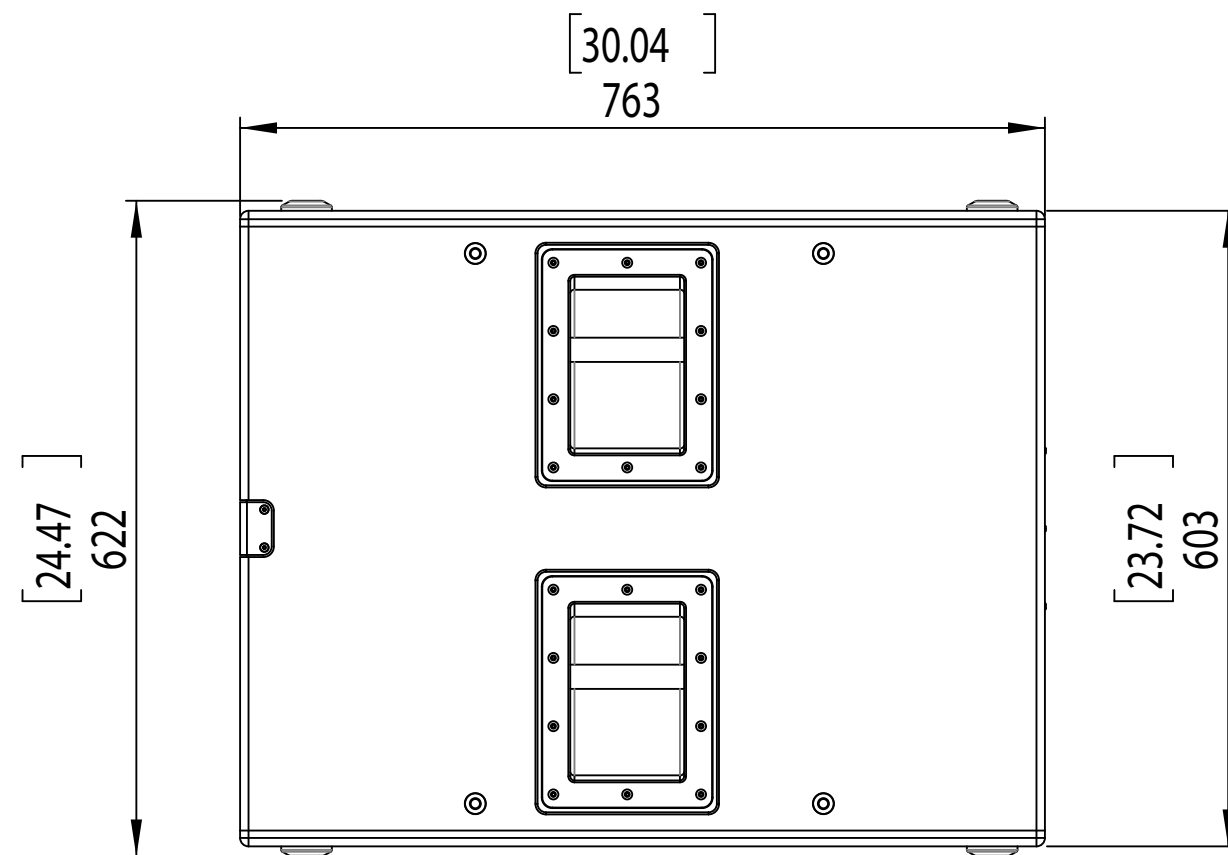
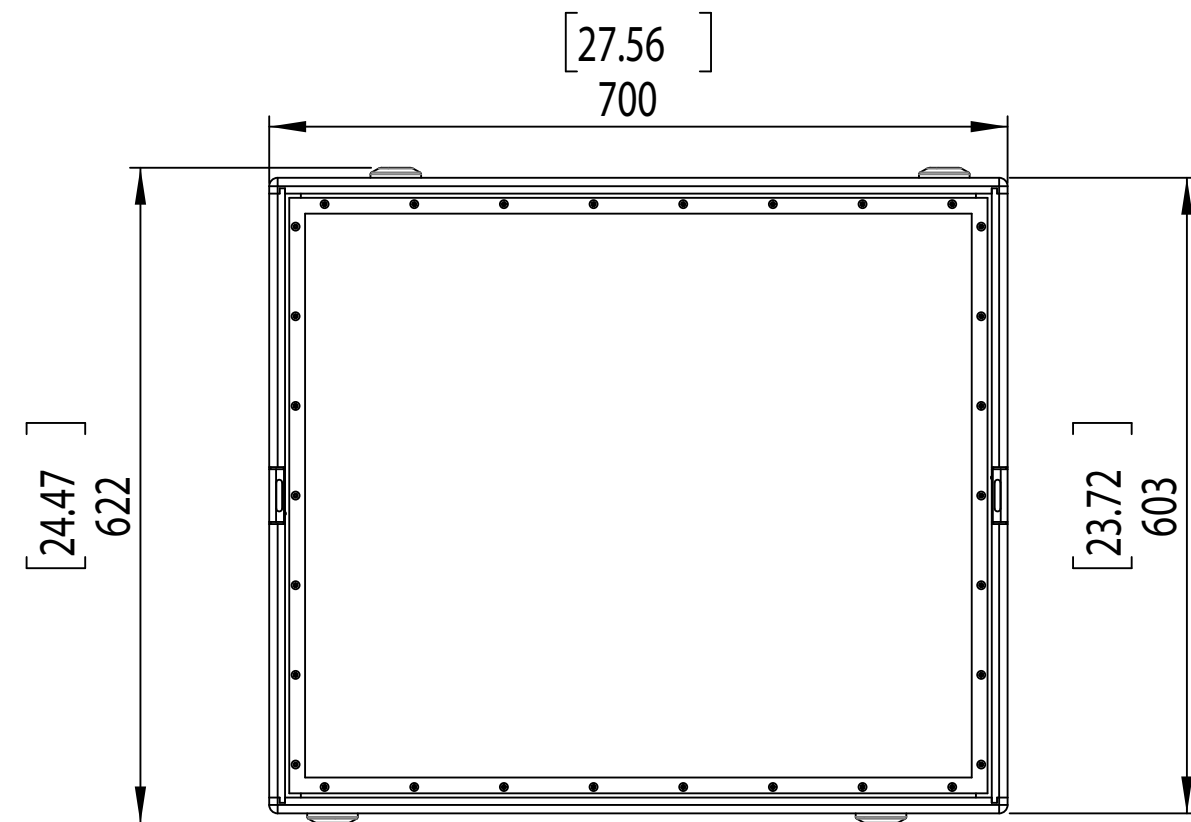

SKU ID: RTB

Material Specification	TITLE: LS118		DWG. NO.		REVISION A
Material: See Part Drawing	Project:		SIZE B	SCALE 1:10	SHEET 1 OF 1
Color: See Part Drawing	Mass: 53800.39	Date: 11/4/2021	Drawn by: Allan V.	Acoustic System Approval: Date:	
Surface Finish: See Part Drawing				Quality Assurance Approval: Date:	
Treatment/Process: See Part Drawing				General Tolerances 0.1~1 ± 0.1 0.01~0.1 ± 0.01 0.001~0.01 ± 0.005	

Critical Dimension

All dimensions are in millimeter(s) unless otherwise indicated. All dimensions and associated leaders, arrows, extensions or other aspects of dimensional callouts are indicated in blue. Checking dimensions are indicated in green and are indicated to assist on classification where deemed necessary by Tectonic Audio Labs. 3D Geometry is provided for reference only - Tectonic Audio Labs provided drawings and documentation indicates official specification.

All parts, assemblies and materials represented on this drawing and the associated drawings or files shall comply to current RoHS, REACH, and Conflict Resource directives and standards. Materials, parts or assemblies found to not comply with RoHS, REACH or the Tectonic Audio Conflict Resource policy shall be judged as nonconforming or reject and subject to return or refund.

4

3

2

1

B

B

A

A