



# **CLEAR-COM ENCORE**

**KB-702/KB-702GM TWO-CHANNEL  
SPEAKER STATIONS**

**INSTRUCTION MANUAL**

## KB-702/KB-702GM Two-Channel Speaker Stations Instruction Manual

Part Number: 810492Z Rev. 4

### Legal Disclaimer

Copyright © 2018 HME Clear-Com Ltd.

All Rights Reserved

Clear-Com, the Clear-Com logo, and Clear-Com Concert are trademarks or registered trademarks of HM Electronics, Inc. The software described in this document is furnished under a license agreement and may be used only in accordance with the terms of the agreement.

The product described in this document is distributed under licenses restricting its use, copying, distribution, and decompilation/reverse engineering. No part of this document may be reproduced in any form by any means without prior written authorization of Clear-Com, an HME Company.

Clear-Com Offices are located in California, USA; Cambridge, UK; Montreal, Canada; and Beijing, China. Specific addresses and contact information can be found on Clear-Com's corporate website:

[www.clearcom.com](http://www.clearcom.com)

### Clear-Com Contacts

#### Americas and Asia-Pacific Headquarters

California, United States

Tel: +1.510.337.6600

Email: [CustomerServicesUS@clearcom.com](mailto:CustomerServicesUS@clearcom.com)

#### Europe, Middle East, and Africa Headquarters

Cambridge, United Kingdom

Tel: +44 1223 815000

Email: [SalesSupportEMEA@clearcom.com](mailto:SalesSupportEMEA@clearcom.com)

#### Canada Office

Quebec, Canada

Tel: +1 (450) 653-9669

#### China Office

Beijing Representative Office

Beijing, P.R.China

Tel: +8610 65811360 / 65815577

# CONTENTS

OPERATION .....	1-1
Introduction .....	1-1
Description .....	1-1
Operation .....	1-2
Front Panel .....	1-2
Internal Adjustments and Connections .....	1-5
INSTALLATION .....	2-1
MAINTENANCE .....	3-1
Block Diagram for the KB-702 .....	3-1
Block Diagram for the KB-702GM .....	3-2
Troubleshooting .....	3-3
TECHNICAL SPECIFICATIONS .....	4-1
KB-702/KB-702GM Two-Channel Speaker Stations .....	4-1
LIMITED WARRANTY .....	5-I
Warranty Period .....	5-i
Technical Support .....	5-i
Warranty Repairs and Returns .....	5-ii
Non-Warranty Repairs and Returns .....	5-ii
Extended Warranty .....	5-ii
Service Contract .....	5-iii
Liability .....	5-iii



# IMPORTANT SAFETY INSTRUCTIONS

*Please read and follow these instructions before operating this product.*

1. Read these instructions.
2. Keep these instructions.
3. Heed all warnings.
4. Follow all instructions.
5. Do not use this apparatus near water.
6. Clean only with dry cloth.
7. Do not block any ventilation openings. Install in accordance with the manufacturer's instructions.
8. Do not install near any heat sources such as radiators, heat registers, stoves, or other apparatus (including amplifiers) that produce heat.
9. Only use attachments/accessories specified by the manufacturer.
10. Use only with the cart, stand, tripod, bracket, or table specified by the manufacturer, or sold with the apparatus. When a cart is used, use caution when moving the cart/apparatus combination to avoid injury from tip-over.
11. Unplug this apparatus during lightning storms or when unused for long periods of time.
12. Refer all servicing to qualified service personnel. Servicing is required when the apparatus has been damaged in any way, such as power-supply cord or plug is damaged, liquid has been spilled or objects have fallen into the apparatus, the apparatus has been exposed to rain or moisture, does not operate normally, or has been dropped.
13. **WARNING:** To reduce the risk of fire or electric shock, do not expose this product to rain or moisture.

**Please familiarize yourself with the safety symbols in Figure 1. When you see these symbols on this product, they warn you of the potential danger of electric shock if the station is used improperly. They also refer you to important operating and maintenance instructions in the manual.**



This symbol alerts you to the presence of uninsulated dangerous voltage within the product's enclosure that might be of sufficient magnitude to constitute a risk of electric shock. Do not open the product's case.



This symbol informs you that important operating and maintenance instructions are included in the literature accompanying this product.

*Figure 1: Safety Symbols*

## **EMC AND SAFETY**

**The KB-702 and KB-702GM stations meet all relevant CE and FCC specifications set out below:**

**EN55103-1 Electromagnetic compatibility. Product family standard for audio, video, audio-visual, and entertainment lighting control apparatus for professional use. Part 1: Emissions.**

**EN55103-2 Electromagnetic compatibility. Product family standard for audio, video, audio-visual, and entertainment lighting control apparatus for professional use. Part 2: Immunity.**

**And thereby compliance with the requirement of Electromagnetic Compatibility Directive 2004/108/EC and Low Voltage Directive 2006/95/EC**

**This device complies with Part 15 of the FCC Rules. Operation is subject to the following two conditions: (1) this device may not cause harmful interference, and (2) this device must accept any interference received, including interference that may cause undesired operation.**

# 1

# OPERATION

## INTRODUCTION

Congratulations and thank you for choosing this Clear-Com product. The KB-702 and KB-702GM two-channel speaker stations are powerful, user-friendly units that can serve as versatile intercom stations.

Please read this manual completely to better understand the functions of these products. For questions not addressed in this manual, contact the dealer or Clear-Com directly. Clear-Com applications support and service people are ready to help.

## DESCRIPTION

The Clear-Com KB-702 is a two-channel speaker station ideal for theatre, live performances, industrial applications, and small TV facilities. It features excellent speech intelligibility even in high-noise environments and can be tailored to your needs through its programmable options.

In addition, the Clear-Com KB-702GM contains a jack for an optional Clear-Com gooseneck panel microphone and a close-in, voice-controlled circuit (VOX). This circuit allows automatic, alternate dipping of the panel microphone and the speaker in response to conversation.

Selectable two-channel talking and/or listening allows the operator to communicate on either of the intercom channels. The dual-action *talk* button is electronic *momentary* or *latching*. Monitoring can be done through the headset, the integral speaker, or both at once. The KB-702 offers both visual and audible call signaling to attract the attention of operators. The *remote mic kill* (RMK) feature on main stations will turn off any open mics on the KB-702.

A balanced program input allows the monitoring of external audio using the headset or speaker. This program input can also be used as a paging function.

The KB-702 speaker station accepts dynamic headsets. A *sidetone* control allows the operator to vary the level of his/her own voice as heard in the headset and speaker.

The integral speaker can be turned on or off by a convenient front panel switch. An automatic speaker dipping circuit will lower the level of the speaker whenever the *talk* button is activated. This feature helps minimize acoustical feedback.

The KB-702 receives power from the Clear-Com intercom line. The unit mounts either in a standard four-gang electrical outlet box or in an optional Clear-Com four-gang V-box. The extra-thick front panel and compact surface-mount circuitry maintains legendary Clear-Com ruggedness. The two intercom channels connect to a plug-on screw terminal strip. Male and female

3-pin XLR connectors are provided on the four-gang V-box for an inline connection to one of the intercom channels.

The KB-702 and KB-702GM are compatible with all Clear-Com party-line intercoms.

## OPERATION

Normal operation of the KB-702 speaker station requires access only to the front panel controls. The controls located elsewhere on the unit are intended to be set-and-forget in nature. For intercom operation, set the *listen level* control to the desired level and press the *talk* button when talking. If a headset or handset is used, set the *sidetone* control for each channel for the desired amount of sidetone in the earphone. If a hand-held push-to-talk mic is used, or if the panel mic is used on the KB-702GM, set the sidetone controls for minimum feed-through to the speaker to prevent acoustic feedback.

## FRONT PANEL

The controls, indicators, and connectors found on the KB-702 and KB-702GM front panels are shown in the following figures and are described by the following text. The numbers in the left column refer to Figure 1-1 and Figure 1-2.

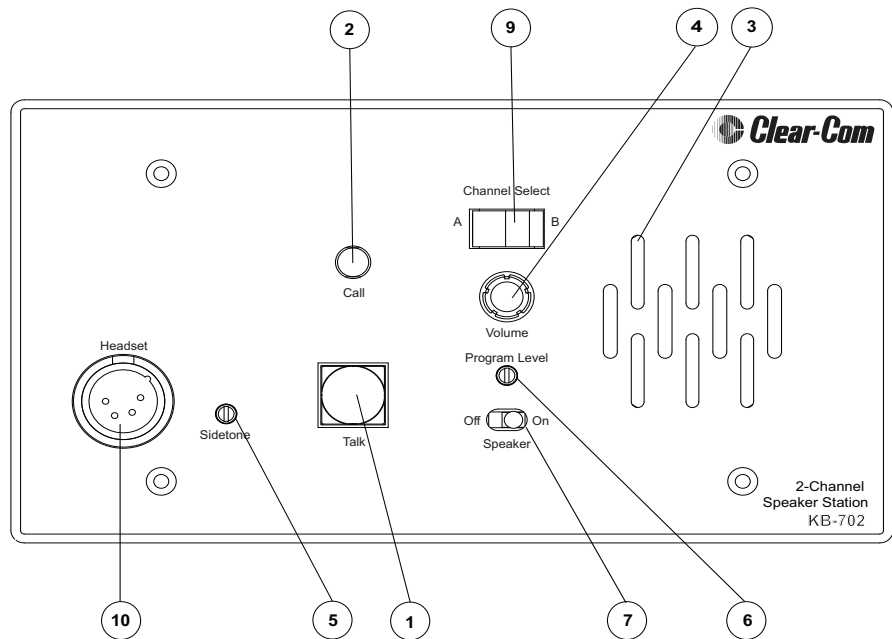

Figure 1-1: KB-702 Front Panel



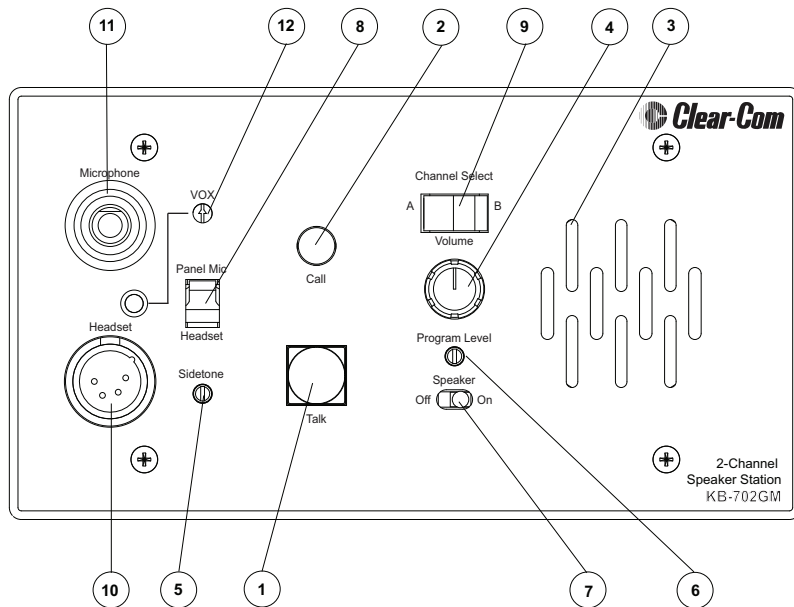

Figure 1-2: KB-702GM Front Panel

1. **Talk Button and Indicator:** The *talk* button activates the microphone feed to the selected intercom channel. It has a dual action (*momentary* or *latching*) depending upon how the button is pressed. If desired, the *latching* function can be defeated using an internal option switch. The following describes the various functions of this button.
  - **MOMENTARY:** Press and hold the *talk* button while you are speaking. Release it when you are finished. The button lights amber when the *talk* function is active and blue when it is inactive.
  - **LATCHING:** Press the button quickly to latch the *talk* function. Press the button again to turn off the *talk* function.
  - **VOX INDICATION:** On the KB-702GM, when the VOX feature is enabled, the *talk* button illuminates amber to indicate an active talk, and the *VOX* light illuminates amber to indicate that the panel microphone is in use. This will automatically dip the speaker.
2. **Call Button and Light:** Pressing the *call* button will send a call signal on the selected channel. All the call lights on that channel will then flash. Call signals can also be sent while talking if required. The call button will light when pressed, or whenever a call signal is present on the selected channel. An internal option jumper can be set to allow the call button to light when a call signal is present on either channel.
3. **Tone Alert:** An audible *tone alert* can be enabled to sound when a call signal is received on the selected channel or either channel. This can be useful when the operator's attention has been drawn away from the KB-702 indicator panel. The audible tone alert level can be adjusted or turned off by an internal control. The tone alert will not sound if a call signal originates at the KB-702 station or if the *speaker on/off* switch is

turned *off*. The tone alert plays through both the speaker and headset if the speaker on/off switch is turned on.

4. **Volume Control:** Turn this control to set the *volume* required on the speaker or headset. This control does not affect the *tone alert* level or the *program input* level.
5. **Sidetone Control:** Sidetone is the level of your own voice that you hear while talking on the intercom. Setting a comfortable level of sidetone will ensure that the intercom line sounds alive and also helps you modulate your voice relative to other voices on the line.

Typically, different *sidetone null* settings are needed depending upon whether you are using the speaker. Use one of the following procedures to correctly set the *sidetone level* control.

**Sidetone Adjustment Procedure for Headset:**

1. Set the *intercom level* control to a comfortable level by having someone talk to you from another station.
2. Press the *talk* button and speak into the microphone while turning the *sidetone null* control slowly back and forth until you hear your voice at a comfortable level in the headset.

**Sidetone Adjustment Procedure for Gooseneck Mic (KB-702GM only) or hand-held push-to-talk mic with the speaker turned on:**

1. Set the *VOX* control fully counterclockwise to disable this feature.
  2. Set the *intercom level* control to a comfortable level.
  3. Press the *talk* button and speak into the microphone while turning the *sidetone null* control slowly back and forth. There should be a point where your voice (and any accompanying acoustic feedback) disappears. This is the null point.
  4. Readjust the *VOX* control. (Refer to the *VOX* control paragraph in this section.)
6. **Program Level Control:** Adjust the *program level* control to set the program audio level heard in the headset or panel speaker.

**Note: Do not force the trim pots past their stop points. This will damage them.**

7. **Speaker On/Off Switch:** The *speaker on/off* switch turns the front panel speaker *on* or *off*. This switch also controls whether the tone alert is heard through the speaker. The speaker volume will automatically dip whenever the talk function is set, unless the *VOX* function is disabled.
8. **Mic Select Switch (KB-702GM only):** The *mic select* switch selects whether the panel microphone or the headset microphone is active. If the *VOX* feature is enabled, it is only operational when the panel microphone is active.
9. **Channel Switch:** This switch selects whether the speaker station is active on intercom channel A or channel B.
10. **Headset Connector:** The headset connector is located on the front panel. All Clear-Com headsets are recommended for use with the KB-702. The Clear-Com handheld push-to-talk microphone will also plug into the

headset connector. The following is a description of the characteristics of a suitable headset:

Mic Type --- Dynamic; see technical specifications for details

Headphone --- Dynamic; see technical specifications for details

The wiring of the headset is to be as follows:

Pin 1 --- Mic common

Pin 2 --- Mic hot

Pin 3 --- Headphone common

Pin 4 --- Headphone hot

The mic and headphone wiring in the headset cord must be individually shielded. **Do not connect pins #1 and #3 together.** Headset extension cords or headset “Y” cables are not recommended because they will increase crosstalk between channels.

11. **Panel Mic Connector (KB-702GM only):** Clear-Com recommends the GM-9 and GM-18 plug-in panel microphones for use with the KB-702GM. The GM-9 is 9 in. (23.04 cm) long and the GM-18 is 18 in. (46.08 cm) long. Both are the electret type. The 1/4 in. (0.64 cm) phone jack on the microphone mates with the *panel mic* receptacle on the front panel of the KB-702GM.

To install a GM-9 or GM-18 microphone, use the following steps:

1. Remove the plastic plug from the jack, if present.
2. Check and unscrew the set screw in the mic mounting flange to make sure it is clear of the threads in the bushing.
3. Screw the microphone into the bushing hand tight.
4. Turn the set screw on top of the mic mounting flange clockwise to lock the microphone in place.

12. **VOX Control (KB-702GM only):** When the panel microphone is selected on the KB-702GM, the *VOX* control should be adjusted for proper operation. This control is located to the right of the panel mic connector. Use a narrow flat blade screwdriver such as a *greenie* or *tweaker* for this adjustment. When the adjustment is correctly set, the *VOX* light illuminates amber when speaking into the panel microphone. Turning the control clockwise makes the KB-702GM more sensitive to your voice. The *VOX* feature can be disabled by turning the *VOX* control fully counterclockwise.

## INTERNAL ADJUSTMENTS AND CONNECTIONS

The controls and connectors found inside the KB-702 are shown in the following figure and described by the following text. The controls can be accessed without completely removing the panel from its wall box or V-Box enclosure by removing the top two screws and loosening the bottom two screws a few turns. Then lean the panel out from the wall. The controls will

then be accessible as shown in the lower view of Figure 1-3. The numbers in the left column of the following descriptions refer to Figure 1-3.

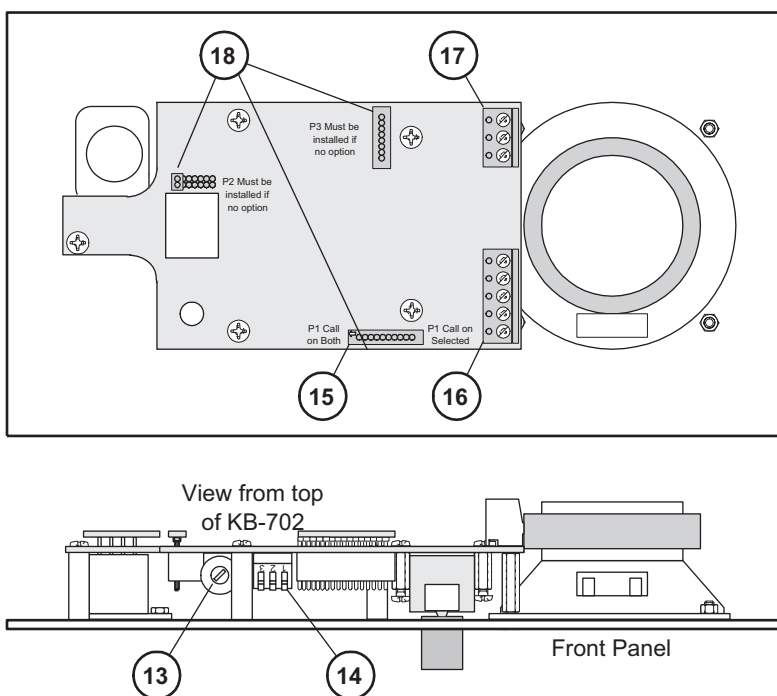
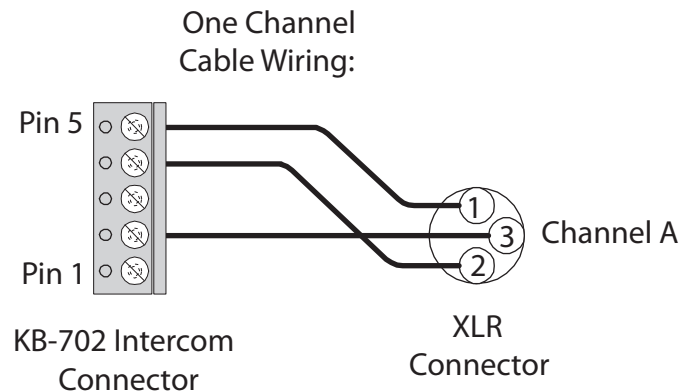

Figure 1-3: Internal Adjustments and Connections

13. **Call Alert Tone Level Control:** This control adjusts the volume of the *call alert tone* sound. This is normally adjusted when the system is set up and there should be no need to adjust it in normal operation. This feature can be disabled by turning the control fully counterclockwise.
14. **Option Switches:** Three *option* switches are provided. They should be configured when the system is set up, but are not changed in normal operation. Note the *on* position of each switch is toward the circuit board and the *off* position is toward the front panel. The default position of the switches is in the *off* position. The function of each switch is as follows:
  1. **SINGLE CHANNEL:** In some installations, the KB-702 is intended to be used only with one intercom channel. Setting the *single channel* switch to the *on* position will connect the KB-702 to the one intercom channel regardless of the position of the front panel channel selector. In two-channel installations, this switch must be set to the *off* position.
  2. **LONG LINE:** If a long cable run is unavoidable and approaches 700 ft. (213.5 m) or more, set the *long line* option switch to the *on* position. The ability to set a sidetone null depends upon properly setting this switch.
  3. **LATCH DISABLE:** Setting the *latch disable* switch to the *on* position will disable the latching function of the *talk* button. In this mode, the talk button must be continuously pressed while the operator is talking.

15. **Call Signal Jumper:** In some installations it is important to receive a *call* signal from either channel, regardless of the setting of the channel selector. The plug-on jumper *P1* makes the *call* light respond to either (a) the selected channel or to (b) either channel, depending upon its orientation. By default, the jumper is set to the selected channel position. When the TW or 4-Wire Option modules are installed, this jumper is not used. In TW operation, the call signal always originates on channel A. In 4-Wire operation, the call signal is not used.
16. **Intercom Line Connection:** The KB-702 contains a 5-terminal plug-on connector for intercom line connection. This connector is intended to be unplugged from the circuit board when connecting the intercom line, and then plugged back on when the wiring is completed. The connections for each pin are visible on the circuit board when the connector is unplugged. The pinout of this connector is as follows:
- Pin 1 --- (NC)
  - Pin 2 --- Channel A Audio
  - Pin 3 --- Channel B Audio
  - Pin 4 --- Power
  - Pin 5 --- Ground (Shield)



*Figure 1-4: One-Channel Cable Wiring*

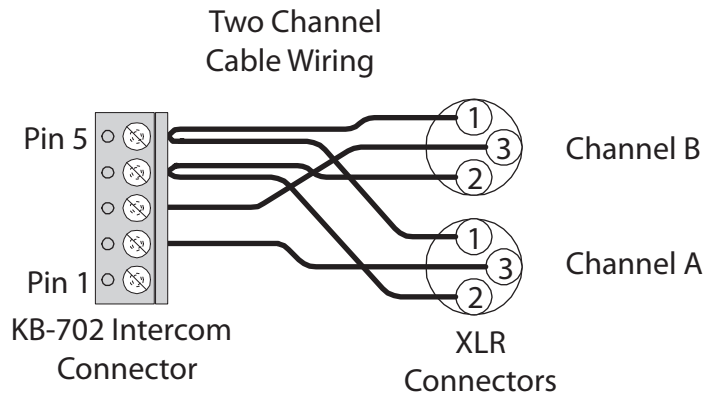

Figure 1-5: Two-Channel Cable Wiring

17. **Program Input:** A 3-terminal plug-on connector provides the program input to the station. Program is fed to the headset and speaker. The level to the speaker or headset is controlled by the *program level* control. The *program input* accepts a balanced or unbalanced line-level audio signal. If this input is connected to the *stage announce (SA)* output of a main station it can be used as a paging input. Since the level of this input is independently adjustable from the intercom audio volume, it can be used to override the intercom audio.

The pinout of the *program input* connector is as follows:

- Pin 1 --- Ground (shield)
- Pin 2 --- + Signal
- Pin 3 --- - Signal

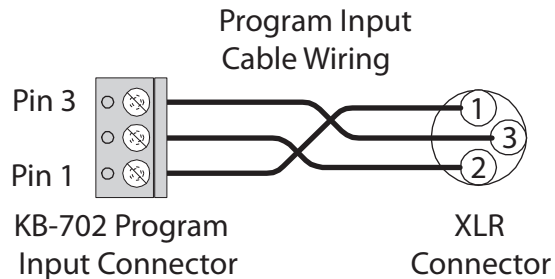

Figure 1-6: Program-Input Cable Wiring

18. **Option Board Jumpers:** The three jumper plugs *P1*, *P2*, and *P3* must be installed when optional modules are not used. When the optional EB7-4W four-wire module is used, both *P1* and *P3* must be removed. In the KB-702GM, *P2* is replaced by the VOX module. Save these jumper plugs for possible future use after removing them. **The KB-702 will not operate without either these jumper plugs or the optional modules installed.**







# 2

## INSTALLATION

1. Unpack the unit and inspect for any damage that may have occurred in shipping.
2. Set the *option* switches to the default (*up*) position.
3. Connect the intercom lines. If only one intercom line is to be connected, turn *option* switch #1 to the *on* or *closed* position.
4. Install the KB-702 into the four-gang outlet box or V-box. (For additional information, refer to the *Clear-Com System Installation Manual*.)
5. Set *listen levels* and *sidetones*. (Refer to the listen level and sidetone setting topics in the Operation chapter of this manual.)
6. The speaker station should now be operating properly.
7. Read the rest of this manual for further information.



# 3 MAINTENANCE

This chapter provides maintenance information including block diagrams and tips for solving problems.

**Caution:** *These servicing instructions are for use by qualified personnel only. To reduce the risk of electrical shock, do not perform any servicing other than that contained in the operating instructions unless you are qualified to do so.*

## BLOCK DIAGRAM FOR THE KB-702

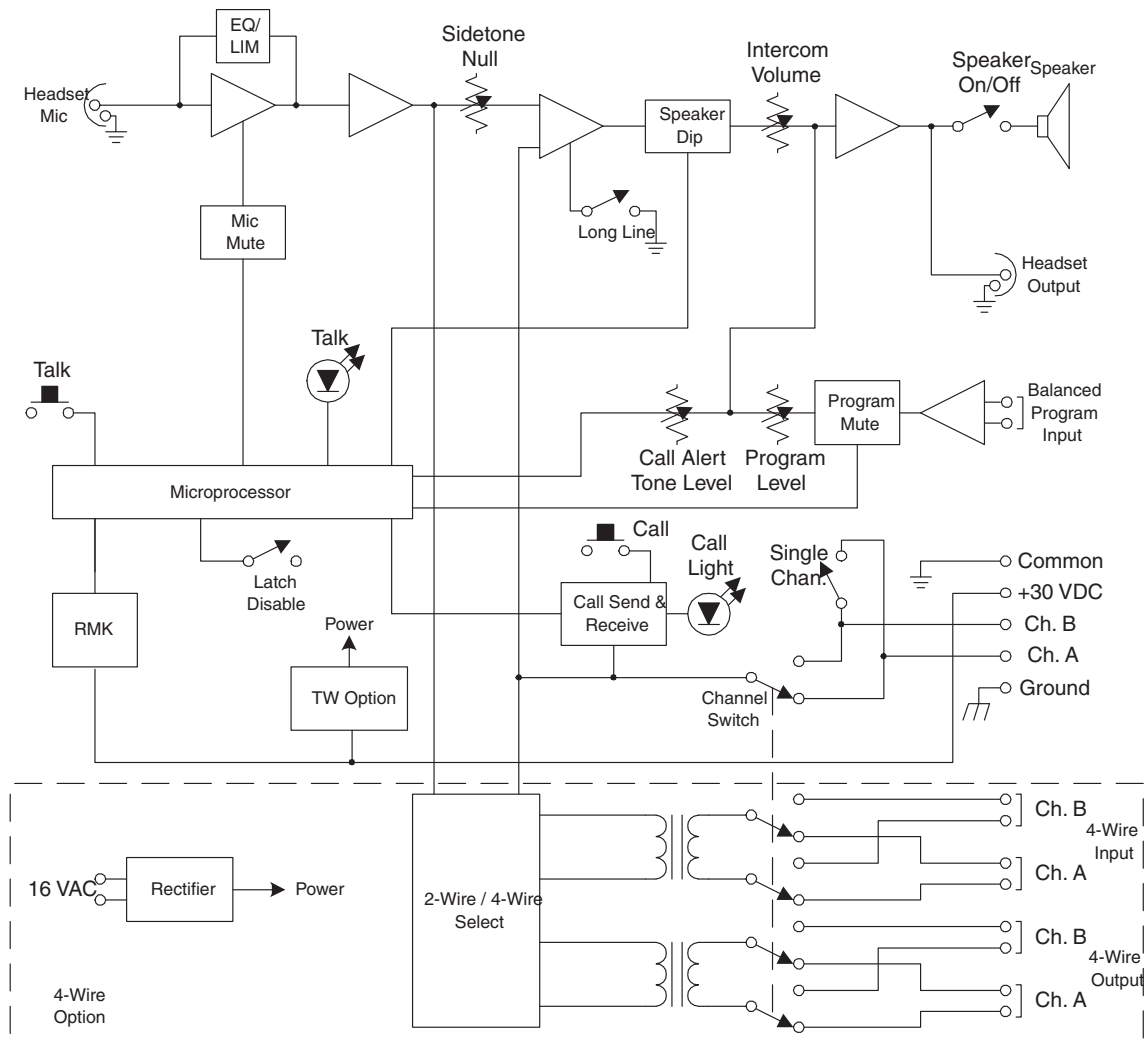

Figure 3-7: KB-702 Block Diagram

# BLOCK DIAGRAM FOR THE KB-702GM

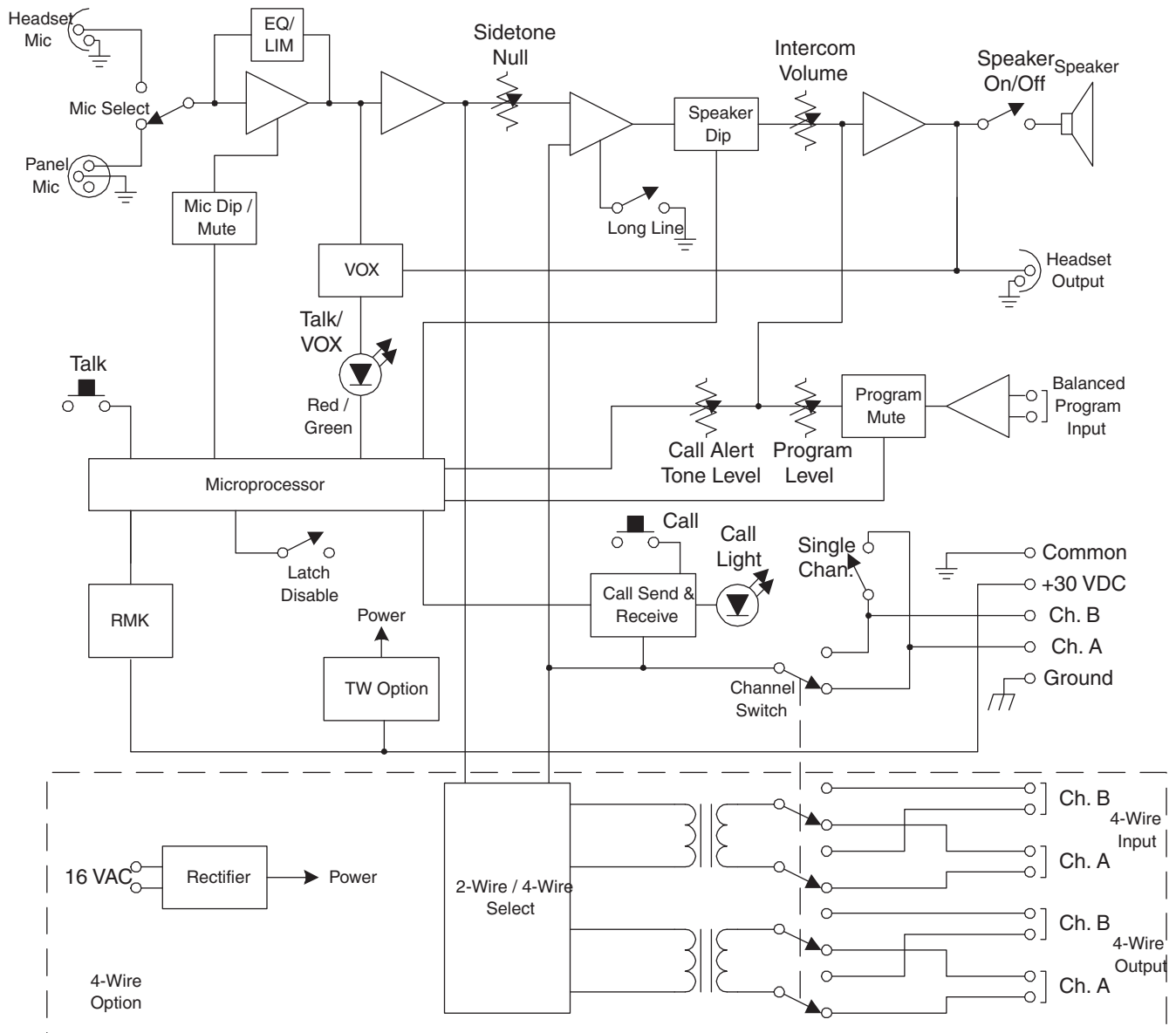

Figure 3-8: KB-702GM Block Diagram

# TROUBLESHOOTING

SYMPTOM	CAUSE	SOLUTION
System does not operate. <i>Talk</i> button does not light.	No intercom connection to the KB-702. If the EB7-4W four-wire option module is connected, the KB-702 may not be receiving AC power.	Check connections and cable.
	The KB-702 has an internal failure.	Unit requires servicing.
Speaker does not operate. <i>Talk</i> button lights amber when pressed.	<i>Speaker</i> switch turned off, <i>volume</i> knob turned all the way down, or <i>channel</i> switch set to unused channel.	Adjust controls appropriately.
	Speaker plug or wiring has come loose.	Make sure speaker is connected internally.
	Plug <i>P3</i> missing on circuit board.	Plug <i>P3</i> must be installed in jack <i>J3</i> if the EB-TW or EB7-4W options are not used.
Hum or buzz in system	Inductive pickup caused by close proximity of this speaker station or connected stations to power lines or transformers.	Relocate the offending unit or wiring. If the cable run is exceptionally long, consider adding and using the EB7-4W four-wire option module. (Requires an additional four-wire interface at the opposite end of the “long run.”)
System feedback (Acoustical)	<i>Intercom level</i> control at this station or another station is set too high.	Adjust.
	<i>Sidetone null</i> control at this station or another station is not adjusted correctly.	Adjust. Refer to the chapter “Operation.”
	Channel not terminated.	Set the <i>main station</i> or <i>power supply termination</i> switch for that channel to the <i>on</i> position.
	Channel switch set to an unconnected channel.	If only one intercom line is connected, set <i>option</i> switch #1 to the <i>on</i> or <i>closed</i> position to link both channel switch positions to the same intercom line.
	A headset extension cord was used.	Headset extension cords are not recommended.

SYMPTOM	CAUSE	SOLUTION
VOX problems (KB-702GM only)	Stays tripped (amber light <i>on</i> ). Sensitivity set too high.	Turn <i>VOX sensitivity</i> control in a counter-clockwise direction.
	Will not trip with voice. Sensitivity set too low.	Turn <i>VOX sensitivity</i> control in a clockwise direction. <b>Note:</b> VOX is intended for close-in operation.
Excessive crosstalk	High DC resistance has a ground return.	Use heavier cable; add additional conductor(s) to ground return. If the cable run is exceptionally long, consider adding and using the EB7-4W four-wire option module.
	<i>Multi-channel</i> cable pairs are not individually shielded.	Replace cable with individually shielded pairs.
	Headset cables are not wired properly or shielded properly.	Correct wiring. Use headsets with properly shielded wiring. Refer to the chapter “Operation.”
Program signal sounds distorted.	<i>Program level</i> control set too high.	Turn the <i>program level</i> control counter-clockwise.
	Overload of <i>program input</i> circuit.	Reduce the gain of the program signal at the source, such as an audio mixer.
Call signal does not function.	Excessive DC loading of intercom line.	Remove any audio transformers or other equipment that may be connected across the intercom line. If equipment other than Clear-Com intercom equipment must be connected to the intercom line, please contact Clear-Com application or service personnel for information or recommendations.
	Far too many terminations on the intercom line.	Check all main stations and power supplies to make sure each intercom channel is terminated at only one point.
	Plug <i>PI</i> missing on circuit board.	Plug <i>PI</i> must be installed in jack <i>J1</i> if the EB7-4W option is not used.







# 4

# TECHNICAL SPECIFICATIONS

## KB-702/KB-702GM TWO-CHANNEL SPEAKER STATIONS

dBu is an absolute measurement. 0 dBu is referenced to 0.775 volts RMS

### Panel Microphone Input (KB-702GM)

Input Type	Electret
Input Impedance	$\geq 2\text{K}\Omega$
Mic Limiter Threshold	$-2\text{dBu} \pm 3\text{dB}$
Mic Limiter Range	$\geq 15\text{dB}$

### Headset Microphone Input

Input Type	Dynamic
Input Impedance	$\geq 1\text{K}\Omega$
Mic Limiter Threshold	$-2\text{dBu} \pm 3\text{dB}$
Mic Limiter Range	$\geq 15\text{dB}$

### Program Line Input

Maximum Level before Clipping	$\geq 20\text{dBu}$
Input Impedance	$\geq 5\text{K}\Omega$

### Headset Output

Load Impedance	$\geq 8\Omega$
Output Impedance	$\leq 25\Omega$
Output Limiter Threshold	$+5\text{dBu} \pm 3\text{dB}$
Maximum Output Level before Distortion	$\geq 17\text{dBu}$

### Speaker Output

Load Impedance	$\geq 4\Omega$
Max Output Level before 1% Distortion	$20\text{dBu} \pm 2\text{dBu}$

### Party Line Output

Off Noise	$< -74\text{dBu}$
Output Impedance	$> 10\text{K}\Omega$

### Party Line Input

Crosstalk	$< -60\text{dB}$
Max level before Clipping	$\geq 12\text{dBu}$
Sidetone Null Capability (KB-702GM only)	$> 25\text{dB}$

## Frequency Response

Panel Mic - Party Line (KB-702GM only)	300 - 16KHz $\pm$ 3dB
Headset Mic - Party Line	300 - 15KHz $\pm$ 3dB
Program Input - Headset Out	200 - 18KHz $\pm$ 3dB
Program Input - Speaker Out	200 - 18KHz $\pm$ 3dB
Party Line - Headset Out	200 - 18KHz $\pm$ 3dB
Party Line - Speaker Out	200 - 18KHz $\pm$ 3dB

## Max Distortion

Panel Mic - Party Line (KB-702GM only)	$\leq$ 0.5%
Headset Mic - Party Line	$\leq$ 0.5%
Program Input - Headset Out	$\leq$ 0.2%
Program Input - Speaker Out	$\leq$ 0.5%
Party Line - Headset Out	$\leq$ 0.2%
Party Line - Speaker Out	$\leq$ 0.5%

## Noise

Panel Mic - Party Line (KB-702GM only)	$<$ -65dBu
Headset Mic - Party Line	$<$ -70dBu
Program Input - Headset Out	$<$ -60dBu
Program Input - Speaker Out	$<$ -60dBu
Party Line - Headset Out	$<$ -50dBu
Party Line - Speaker Out	$<$ -50dBu

## Max Gain

Panel Mic - Party Line (KB-702GM only)	$\geq$ 37dB
Headset Mic - Party Line	41dB $\pm$ 2dB
Program Input - Headset Out	$\geq$ 18dB
Program Input - Speaker Out	$\geq$ 24dB
Party Line - Headset Out	$\geq$ 34dB
Party Line - Speaker Out	$\geq$ 40dB

## Power

Input Voltage Range	20-30 VDC
Input Current (Idle)	$\leq$ 90mA
Input Current (Max)	$\leq$ 110mA

## Internal Adjustments and Connections

Intercom: Line	Five terminal connector
Program Input	Three terminal connector
Option Switches	Three DIP switches
Call Signal Jumper <sup>3</sup>	Three sets of options jumpers
Call Alert Tone Level Control	Level adjustment control

## Front Panel Connectors

Panel Mic: (KB-702GM only)	(1) 1/4 in. (0.64 cm) panel mounting jack
Headset:	(1) XLR-4M

## Front Panel Controls & Indicators (KB-702GM)

- (1) Panel / headset mic switch
- (1) Program monitor level control
- (1) Sidetone null control
- (1) Talk button
- (1) Call button
- (1) Speaker ON-OFF switch
- (1) Channel select switch
- (1) Speaker volume control
- (1) VOX control
- (1) VOX indicator

## Front Panel Controls & Indicators (KB-702)

- (1) Program monitor level control
- (1) Sidetone null control
- (1) Talk button
- (1) Call button
- (1) Speaker ON-OFF switch
- (1) Channel select switch
- (1) Speaker volume control

## Environmental

32 - 122° F (0 - 50° C)

## Dimensions (KB-702/KB-702GM)

8.25 in. W x 4.5 in. H x 1.75 in. D  
(210 mm x 114 mm x 44 mm)

## Weight

KB-702	0.99 lbs. (0.45 Kg)
KB-702GM	1.1 lbs.(0.50 Kg)

## Notice About Specifications

While Clear-Com makes every attempt to maintain the accuracy of the information contained in its product manuals, that information is subject to change without notice. Performance specifications included in this manual are design-center specifications and are included for customer guidance and to facilitate system installation. Actual operating performance may vary.



## LIMITED WARRANTY

Clear-Com warrants that at the time of purchase, the equipment supplied complies with any specification in the order confirmation when used under normal conditions, and is free from defects in workmanship and materials during the warranty period.

*Clear-Com offers 24 x 7 customer support if you have an Extended Warranty or Service Contract.*

During the warranty period Clear-Com, or any service company authorized by Clear-Com, will in a commercially reasonable time remedy defects in materials, design, and workmanship free of charge by repairing, or should Clear-Com in its discretion deem it necessary, replacing the product in accordance with this limited warranty. In no event will Clear-Com be responsible for incidental, consequential, or special loss or damage, however caused.

*Return Material Authorization (RMA) numbers are required for all returns.*

*Both warranty and non-warranty repairs are available.*

## WARRANTY PERIOD

The product may consist of several parts, each covered by a different warranty period. The warranty periods are:

- Cables, accessories, components, and consumable items have a limited warranty of 90 days.
- Headsets, handsets, microphones, and spare parts have a limited warranty of one year.
- UHF wireless IFB products have a limited warranty of one year.
- UHF wireless intercom systems have a limited warranty of three years.
- All other Clear-Com and Drake brand systems and products, including beltpacks, have a limited warranty of two years.

The warranty starts at the time of the product's original purchase. The warranty start date for contracts which include installation and commissioning will commence from the earlier of date of the Site Acceptance Test or three months from purchase.

## TECHNICAL SUPPORT

To ensure complete and timely support to its customers, Clear-Com's User Support Center is staffed by qualified technical personnel. Telephone and email technical support is offered worldwide by the User Support Center.

The User Support Center is available to Clear-Com's customers during the full course of their warranty period. Telephone support during the warranty period will be offered at no charge between 09:00 and 17:00 according to the customer's local time zone.

In addition, for customers who purchase an Extended Warranty or Service Contract, 24-hour customer support is offered immediately upon purchase of such agreement. For more information, contact your authorized dealer, distributor, or sales representative.

Instructions for reaching Clear-Com's User Support Centers are given below.

**Americas and Asia-Pacific Headquarters California, United States** Tel: +1.510.337.6600 Email: CustomerServicesUS@clearcom.com

**Europe, Middle East, and Africa Headquarters Cambridge, United Kingdom** Tel: +44 1223 815000 Email: SalesSupportEMEA@clearcom.com

**Canada Office Quebec , Canada** Tel: +1 (450) 653-9669

**China Office Beijing Representative Office Beijing, P.R.China** Tel: +8610 65811360 / 65815577

Once the standard warranty period has expired, the User Support Center will continue to provide telephone support if you have purchased an Extended Warranty or Service Contract. In these cases, you will have access to telephone support 24 hours per day, 7 days per week.

## WARRANTY REPAIRS AND RETURNS

Before returning equipment for repair, contact a User Support Center to obtain a Return Material Authorization (RMA). Clear-Com representatives will give you instructions and addresses for returning your equipment. You must ship the equipment at your expense, and the support center will return the equipment at Clear-Com's expense.

For out-of-box failures, use the following contact information:

**Americas and Asia-Pacific Headquarters California, United States** Tel: +1.510.337.6600 Email: CustomerServicesUS@clearcom.com

**Europe, Middle East, and Africa Headquarters Cambridge, United Kingdom** Tel: +44 1223 815000 Email: SalesSupportEMEA@clearcom.com

**Canada Office Quebec , Canada** Tel: +1 (450) 653-9669

**China Office Beijing Representative Office Beijing, P.R.China** Tel: +8610 65811360 / 65815577

Clear-Com has the right to inspect the equipment and/or installation or relevant packaging.

## NON-WARRANTY REPAIRS AND RETURNS

For items not under warranty, you must obtain an RMA by contacting the User Support Center. Clear-Com representatives will give you instructions and addresses for returning your equipment.

You must pay all charges to have the equipment shipped to the support center and returned to you, in addition to the costs of the repair.

## EXTENDED WARRANTY

If you purchase an Extended Warranty, you are also given access free of charge to the User Support Center 24 hours a day, 7 days a week.

You can purchase an extended warranty at any time during the first two years of ownership of the product. The purchase of an extended warranty extends to five years the warranty of any product offered with a standard two-year warranty. The total warranty period will not extend beyond five years. Any purchase of an extended warranty provides 24 x 7 customer support in addition to the warranty immediately upon purchase of the warranty extension.

**Note:** Clear-Com does not offer warranty extensions on UHF wireless intercom systems, or on any product with a 1-year or 90-day warranty.

## SERVICE CONTRACT

Clear-Com also offers service contracts that provide 24 x 7 telephone support, advance replacements, training, proactive maintenance, on-site visits, and no charge for repair or replacement of equipment. For more information, contact your authorized dealer, distributor, or sales representative.

## LIABILITY

THE FOREGOING WARRANTY IS CLEAR-COM'S SOLE AND EXCLUSIVE WARRANTY. THE IMPLIED WARRANTY OF MERCHANTABILITY AND FITNESS FOR A PARTICULAR PURPOSE AND ANY OTHER REQUIRED IMPLIED WARRANTY SHALL EXPIRE AT THE END OF THE WARRANTY PERIOD. THERE ARE NO OTHER WARRANTIES (INCLUDING WITHOUT LIMITATION WARRANTIES FOR CONSUMABLES AND OTHER SUPPLIES) OF ANY NATURE WHATSOEVER, WHETHER ARISING IN CONTRACT, TORT, NEGLIGENCE OF ANY DEGREE, STRICT LIABILITY OR OTHERWISE, WITH RESPECT TO THE PRODUCTS OR ANY PART THEREOF DELIVERED HEREUNDER, OR FOR ANY DAMAGES AND/OR LOSSES (INCLUDING LOSS OF USE, REVENUE, AND/OR PROFITS). SOME STATES DO NOT ALLOW THE EXCLUSION OR LIMITATION OF INCIDENTAL OR CONSEQUENTIAL DAMAGES OR THE LIMITATION ON HOW LONG AN IMPLIED WARRANTY LASTS, SO THE ABOVE LIMITATIONS MAY NOT APPLY TO YOU. IN ANY

EVENT, TO THE MAXIMUM EXTENT PERMITTED UNDER APPLICABLE LAW, CLEAR-COM'S LIABILITY TO CUSTOMER HEREUNDER SHALL NOT UNDER ANY CIRCUMSTANCES EXCEED THE COST OF REPAIRING OR REPLACING ANY PART(S) FOUND TO BE DEFECTIVE WITHIN THE WARRANTY PERIOD AS AFORESAID.

This warranty does not cover any damage to a product resulting from cause other than part defect and malfunction. The Clear-Com warranty does not cover any defect, malfunction, or failure caused beyond the control of Clear-Com, including unreasonable or negligent operation, abuse, accident, failure to follow instructions in the manual, defective or improperly associated equipment, attempts at modification and repair not approved by Clear-Com, and shipping damage. Products with their serial numbers removed or defaced are not covered by this warranty.

This warranty does not include defects arising from installation (when not performed by Clear-Com), lightning, power outages and fluctuations, air conditioning failure, improper integration with non-approved components, defects or failures of customer furnished components resulting in damage to Clear-Com provided product.

This limited warranty is not transferable and cannot be enforced by anyone other than the original consumer purchaser.

This warranty gives you specific legal rights and you may have other rights which vary from country to country.