

# ETC Installation Guide

## ColorSource PAR jr

---

### Overview

The ColorSource PAR jr is an affordable LED fixture that uses the RGB-L (red, green, blue, and lime) color system to provide a rich, bright light.

The ColorSource PAR jr is available in both original and Deep Blue variants. The Deep Blue uses an array that offers richer, more saturated blues and stronger magentas in exchange for the more jewel-toned blues like sky or turquoise. For more information, see the ETC website at [etcconnect.com](https://www.etcconnect.com).

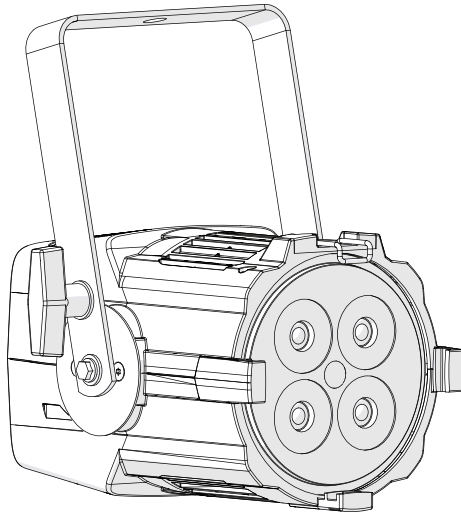

**Note:** Features described in this document require the latest version of software. For information on updating fixture software, see [Update the Fixture Software on page 9](#).

---



---

Corporate Headquarters ■ Middleton, WI, USA | +1 608 831 4116  
Global Offices ■ London | Rome | Holzkirchen | Paris | Hong Kong | Dubai | Singapore  
New York | Orlando | Los Angeles | Austin | © 2024 Electronic Theatre Controls, Inc.  
Web [etcconnect.com](https://www.etcconnect.com) | Support [support.etcconnect.com](https://support.etcconnect.com)  
Contact [etcconnect.com/contactETC](https://www.etcconnect.com/contactETC) | Trademark and patent info: [etcconnect.com/ip](https://www.etcconnect.com/ip)  
Third-party license agreement info: [etcconnect.com/licenses](https://www.etcconnect.com/licenses) | Product information and specifications subject to change. ETC intends this document to be provided in its entirety.  
7420M2100 Rev C Released 2024-03

# ETC Installation Guide

## ColorSource PAR jr

---

### Safety

For professional use only. Read the entire manual before using this equipment.

---



#### **WARNING:**

- Risk of eye injury. Do not stare directly into the light.
- Do not mount the fixture on or near a flammable surface.
- When the fixture is mounted, the axis between the yoke attachment points must be parallel to the ground. Mounting the fixture in a non-parallel orientation risks property damage or bodily injury.
- Disconnect the fixture from power and DMX and allow it to cool before installing accessories or performing any cleaning and maintenance.
- To reduce the risk of strangulation, secure any fixture cords to the mounting structure if the cords are within arm's reach.

#### **AVERTISSEMENT :**

- Risque de lésion oculaire. Ne fixez pas directement la lumière.
  - Ne pas installer le projecteur sur ou à côté d'une surface inflammable.
  - Lorsque le luminaire est accroché, l'axe entre les points de fixation de la lyre doit être parallèle au sol. Le montage du luminaire dans une orientation non parallèle risque de causer des dommages matériels ou corporels.
  - Débranchez le projecteur de son alimentation et du DMX et laissez-le refroidir avant d'installer des accessoires ou d'effectuer un nettoyage ou un entretien.
  - Pour réduire le risque d'étranglement, fixez tous les câbles du luminaire à la structure de montage si les cordons sont à portée de main.
-

# ETC Installation Guide

## ColorSource PAR jr



**WARNING: RISK OF ELECTRIC SHOCK! The light source in this luminaire is not user-replaceable, and must be replaced only by a qualified technician. Contact ETC Customer Support for assistance.**

**AVERTISSEMENT : RISQUE DE DÉCHARGE ÉLECTRIQUE! La source lumineuse de ce projecteur n'est pas remplaçable par l'utilisateur et ne doit être remplacée seulement par un technicien qualifié. Contactez le service client ETC pour obtenir de l'assistance.**

The following symbols may appear on product labeling.

	<p>The luminaire must be installed at least 0.1 m (4.0 in) away from all lighted objects.</p>	<p>Le luminaire doit être installé à au moins 0,1 m (4,0 po) de tout objet éclairé.</p>
	<p>Do not mount the fixture on or near a flammable surface.</p>	<p>Ne pas installer le projecteur sur ou à côté d'une surface inflammable.</p>
	<p>Do not stare at the operating light source.</p>	<p>Ne pas regarder la source de lumière lorsqu'elle fonctionne.</p>
	<p>This product should not be discarded as unsorted waste but must be sent to separate collection facilities for recovery and recycling.</p>	<p>Ce produit ne doit pas être jeté avec les déchets ménagers mais doit être déposé dans une collecte de déchets électroniques ou dans un point de collecte.</p>

## Installation

### Mounting

The ColorSource PAR jr ships with a standard yoke for mounting with a clamp. You can also order a floor stand yoke (part number 7420K1001) for the ColorSource PAR jr (see image below).

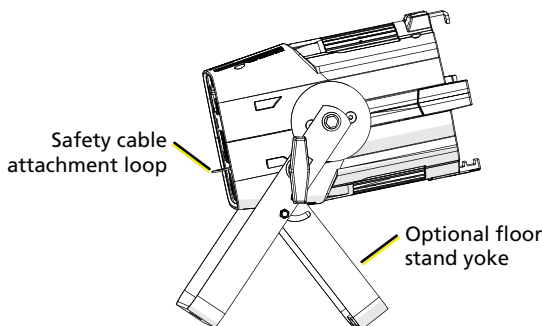

# ETC Installation Guide

## ColorSource PAR jr

---

### Safety Cable

A safety cable (or other approved safety device) must be attached to the fixture. The attachment loop is on the rear of the fixture. Leave as little slack as possible in the safety cable to avoid catching the yoke of the fixture.

### Connectors

- **Power:** Two powerCON® connectors for power in and thru
- **Data (DMX512/RDM):** Two five-pin XLR connectors for data in and thru



**Note:** *The ColorSource PAR jr is not self terminating. You must terminate the last fixture in line with a 120 Ohm resistor. To purchase a terminator, please contact ETC customer service and request part number SGE1507 (XLR terminator).*

---

### Set Up the Fixture

1. Plug the power cord into the powerCON In connector on the rear of the fixture.
2. Make any power-thru cable connections prior to applying a power source.
3. Make any DMX connections, and if the fixture is the last in a DMX line, terminate the fixture. See [Connectors above](#).
4. Plug the power cord into the power source.

### Power Up

Press any button to wake the display. The display shows the DMX address. See [Set the DMX Address on the facing page](#).

You can press the **Mode** button to access the Presets/Sequences menu. See [Play Presets and Sequences on page 7](#).

### Adjust the Tilt

The fixture can be tilted up and down and rotated (panned) as needed.

1. Loosen, but do not remove the yoke locking knob.
2. Tilt the fixture to the desired angle.
3. Tighten the yoke locking knob.

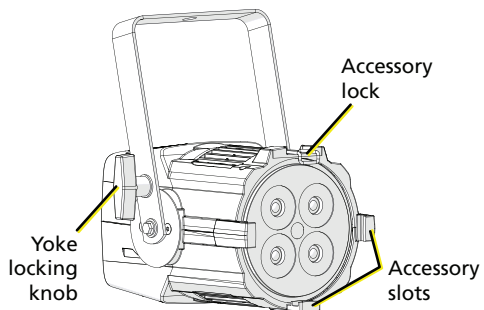

# ETC Installation Guide

## ColorSource PAR jr

---

### Accessories

You can insert two accessories in the accessory slot. For available accessories, see the ColorSource PAR jr datasheet at [etconnect.com](http://etconnect.com).

### Set the DMX Address

1. Press any button to wake the display. The display shows the DMX address.
2. Use the **Up** and **Down** buttons to select the DMX address for the fixture.

You can also use RDM for DMX addressing. See [RDM Values on page 11](#).

### Change the DMX Control Mode

You can set the DMX control mode for the fixture to one of four available mode options.

1. Press any button to wake the display. The display shows the DMX address.
2. Press and hold the **Mode** button for 3 seconds. The display shows the current DMX control mode.
3. Press the **Up** button or **Down** button to change the DMX control mode. (The currently saved mode is indicated by a decimal point at the end of the mode name.)
  - **5ch**: 5-channel mode (intensity, red, green, blue, and strobe). This is the default mode.
  - **d ir**: Direct emitter control (intensity, red, green, blue/indigo, lime, and strobe).
  - **lch**: 1-channel mode controls the intensity of preset 1 (defaults to 3200 K White).
  - **rGb**: RGB mode (red, green, and blue).
4. Press the **Mode** button to confirm your selection.

If you do not press the **Mode** button, the display will automatically return to the DMX address after 10 seconds of inactivity, and edits will not be saved. This cancels unsaved changes.

# ETC Installation Guide

## ColorSource PAR jr

---

### DMX Control Channels

DMX Channel	5ch (5 channel)	dir (Direct)	1ch (1 Channel)	rgb (RGB)
1	Intensity	Intensity	Intensity	Red
2	Red	Red		Green
3	Green	Green		Blue
4	Blue	Blue/Indigo*		
5	Strobe**	Lime		
6		Strobe**		

\*Original ColorSource PAR jr fixture uses blue in channel 4; Deep Blue fixture uses indigo in channel 4.

\*\*Use DMX values of 0 or 255 for no strobe. Use values of 1–254 to increase the strobe rate from 1 per second up to 33 per second.

### Data Loss Behavior

When DMX data is lost, the fixture does one of the following actions:

- If you selected a preset or sequence, that preset or sequence automatically plays.
- If no preset or sequence is active in the background, the fixture goes dark and the DMX start address flashes on the user interface.

### Lock the User Interface

After you have set up the fixture, you can lock the user interface to prevent additional changes.

1. Press and hold the **Up** button and **Down** button simultaneously for 3 seconds. The display will show **Loc** to indicate that the user interface is locked.
2. To unlock the user interface, press and hold the **Up** button and **Down** button simultaneously for 3 seconds.

# ETC Installation Guide

## ColorSource PAR jr

---

### Play Presets and Sequences

The fixture has twelve factory-configured presets and five factory-configured sequences. When you play a preset or sequence on a fixture:

- The same preset number or sequence number plays on any connected fixtures that are not receiving DMX.
- If you power down the fixture, the preset or sequence resumes when you power it on again.

You can re-record presets and sequences through an RDM device or manually on the fixture. See [Re-record Presets on the next page](#).

1. Press the **Mode** button to activate the Presets/Sequences menu. The last active preset or sequence plays automatically. (If DMX data is present, the current preset or sequence plays in the background and DMX data continues to take priority.)
2. Press the **Up** button or **Down** button as needed to scroll through the available presets and sequences.
3. To stop the selected preset or sequence, press the **Mode** button a second time. The display will revert to show the DMX start address.

### Pre-configured Presets

Preset	Name
1	3200 K White
2	5600 K White
3	Red
4	Green
5	Blue
6	Cyan

Preset	Name
7	Magenta
8	Yellow
9	Orange
10	Light Yellow
11	Light Blue
12	Light Pink

### Pre-configured Sequences

Sequence	Name
1	Rainbow Fast
2	Rainbow Slow
3	Warm Colors Fast
4	Cool Colors Fast
5	Random

# ETC Installation Guide

## ColorSource PAR jr

---

### Re-record Presets

1. Using DMX, set the desired levels for the new preset.
2. Press the **Mode** button to access the Presets/Sequences menu.
3. Press the **Up** button or **Down** button to navigate to the preset number that you want to re-record.
4. Press and hold the **Mode** button for 3 seconds to confirm the preset selection. The user interface will show a 3-second countdown. The preset number blinks once to confirm that the preset has been recorded.



**Note:** When the fixture is in Direct mode (**d ir**) or 1-channel mode (**lch**), you cannot re-record presets.

When you re-record presets with the fixture in RGB mode (**r**9b****), the intensity is set to full and the strobe is turned off.

See [Change the DMX Control Mode on page 5](#).

---

### Adjust the Intensity of Presets

1. Ensure that DMX data is not present.
2. Press the **Mode** button to access the Presets/Sequences menu, and then press the **Up** button or **Down** button to select the preset that you want to edit.
3. Press and hold the **Mode** button for 3 seconds. The display shows **L=** followed by either an intensity level from **0-99** or **FL** for full.
4. Press the **Up** button or **Down** button to change the intensity level of the preset in real time.
5. Press the **Mode** button to confirm your selection and return to the Presets/Sequences menu. (If you don't press the **Mode** button, the display returns to the Presets menu after 10 seconds without saving your changes.)



# ETC Installation Guide

## ColorSource PAR jr

---

### Troubleshooting

#### Update the Fixture Software

ETC recommends using UpdaterAtoR software to manage software updates. For information on UpdaterAtoR, see the *UpdaterAtoR Software Quick Guide* and the *UpdaterAtoR Software Release Note*, which you can download from [etconnect.com](http://etconnect.com).

You can push newer software versions from a connected fixture to other ColorSource PAR jr fixtures of the same type.

---



**Note:** *If you have other types of fixtures in your DMX run, you do not need to disconnect them before pushing the updated fixture software. The update process will ignore any other fixture types in the DMX run.*

---



**Note:** *Not sure what version of fixture software is installed? The version number appears on the display when the fixture powers up.*

---

1. Remove power and DMX In from the fixture that is running the software version that you want to push to other fixtures.
2. Press and hold the **Up** button and **Down** button simultaneously while restoring power.
3. The display shows **Udt rdy** to indicate the update mode is selected.
4. Press the **Mode** button to start the update process.
  - The first time that you push an updated software version, additional required files must be copied before the update can begin. The display alternates between **Udt** and **c=HH** to indicate the percentage complete while required data is copied.
  - The display alternates between **Udt** and the percentage complete while updating the connected fixtures.
  - The display returns to its previous value (DMX address or active preset) to indicate that the update is complete.
5. Reconnect DMX In on the fixture.

#### Restore Factory Defaults

Press and hold the **Mode** button, **Up** button, and **Down** button simultaneously for 3 seconds. The DMX start address will blink once to confirm that defaults have been restored.

# ETC Installation Guide

## ColorSource PAR jr

---

### Error Codes

These error codes may display on the user interface.

- **CAL**: Screen toggles between **CAL** and **Err** to indicate a problem with the color calibration. The fixture will need to be returned to the ETC factory; contact your local dealer to set up a repair.
- **OTP**: Screen toggles between **OTP** and **Err** to indicate that the fixture has gone into over-temperature protection mode to avoid damaging the fixture. Once the fixture has self-cooled, the error will automatically clear. If the error does not clear, contact ETC Technical Support (visit [etconnect.com/contactETC](http://etconnect.com/contactETC)).
- **no APP**: Screen toggles between **no** and **APP** to indicate that the upgraded fixtures have a software issue. Reload software to clear the error. If the error persists, contact ETC Technical Support (visit [etconnect.com/contactETC](http://etconnect.com/contactETC)).

### Specifications and Reference

For current and complete compliance and specifications, see the ColorSource PAR jr datasheet at [etconnect.com](http://etconnect.com).

### Environment

The ColorSource PAR jr operates in ambient temperatures of 0°C–40°C. The ColorSource PAR jr is for indoor use only.

- Maximum recommended ambient operating temperature:  
Ta = 40°C (104°F)
- Maximum anticipated external surface temperature at 40°C ambient: Tmax = 80°C (176°F)
- External temperatures after 5 minutes of full-brightness operation at 25°C (77°F) ambient: 36°C (97°F)
- External Temperature (steady state achieved) at 25°C (77°F): 58°C (136°F)

# ETC Installation Guide

## ColorSource PAR jr

---

### Electrical

- Operates between 100 V and 240 VAC at a frequency of 50/60 Hz. See fixture label for details.
- Maximum power consumption is 80 W.
- Up to 17 luminaires (15 A max) may be linked via power thru connector (18 luminaires total per circuit) when used with an R20 Relay Module or Unison Echo Relay Panel. Consult breaker trip curves when used with other equipment. Requires power from a non-dimmable source.
- Inrush:
  - 120 V: 15 A (first half-cycle)
  - 240 V: 29 A (first half-cycle)

### Typical Power Consumption

	100 V		120 V		230 V	
	Power	Current	Power	Current	Power	Current
Idle	5.7 W	0.08 A	5.8 W	0.08 A	4.9 W	0.08 A
Direct at Full	72.0 W	0.72 A	71.6 W	0.60 A	71.4 W	0.34 A

### RDM Values

Parameter	Value	Description
Manufacturer ID	0x6574	Electronic Theatre Controls
Model ID	0x021D	ColorSource PAR jr
	0x021E	ColorSource PAR jr Deep Blue
DMX Start Address	0x00F0	Range = 1–512
DMX Personality	0x00E0	1 = 5 Channel 2 = Direct 3 = 1 Channel 4 = RGB
Output Frequency	0x8123	0 = Standard (1.2 kHz) 1 = High (25 kHz)

# ETC Installation Guide

## ColorSource PAR jr

---

### FCC Compliance

#### ColorSource PAR jr

(For any FCC matters):

Electronic Theatre Controls, Inc.  
3031 Pleasant View Road  
Middleton, WI 53562  
+1 (608) 831-4116  
[etconnect.com](http://etconnect.com)

This device complies with Part 15 of the FCC Rules. Operation is subject to the following two conditions: (1) this device may not cause harmful interference, and (2) this device must accept any interference received; including interference that may cause undesired operation. Visit [etconnect.com/products](http://etconnect.com/products) for current and complete compliance information including FCC compliance.

---



**Note:** *This equipment has been tested and found to comply with the limits for a Class A digital device, pursuant to Part 15 of the FCC rules. These limits are designed to provide reasonable protection against harmful interference when the equipment is operated in a commercial environment. This equipment generates, uses, and can radiate radio frequency energy and, if not installed and used in accordance with the instructions, may cause harmful interference to radio communications. Any modifications or changes to this product not expressly approved by Electronic Theatre Controls, Inc. could void the user's authority to operate the product. Operation of this equipment in a residential area is likely to cause harmful interference, in which case the user will be required to correct the interference at their own expense.*

---