

CANTO is the trusted name in modern follow spots. Bright, modular, and ease of use are the trademarks of this economical line of units that can go anywhere and perform multiple tasks. The Italian design is simple and elegant with ergonomic handling and easy to understand labeling. It's all-in-one ordering system guarantees that the unit is delivered with everything needed to plug the fixture into the wall and begin your show. Canto followspots are great for schools, universities, professional theater, touring and houses of worship.

## Whats in the Box

- Follow Spot Fixture
- Electronic Dimmer
- Iris
- Tripod Stand
- RGBW LED Engine
- Electronic Power Supply
- Power Cable
- 15 Amp Edison
- 28mm Spigot
- Color Control by Android or IOS mobile device connected to proprietary Wi-Fi access point (1 device only, 36 ft range) or remote DMX512/RDM interface.
- USB port supplied to recharge your mobile device while operating the followspot.
- Assurance that it works!

## Accessories/Options

- Spare Iris Diaphragm
- Gobo Holder (A or B)
- Black Stand Tripod
- Tripod Casters
- Custom Flight Case
- Custom Permanent Floor Stand
- Truss Mount Pan Bearing Adaptor
- Over Hung Yoke
- 28mm Spigot
- TelRad
- Shutter Blades
- Professional Tripod Stand

## Unit Stats

- Double Condenser+ Zoom
- Internal Ballast
- 8° to 22° Zoom
- 100V-260V
- 2.34 Amps
- Head 44 lbs.



## Lamp Types

RGBW LED	3000K or 6000K	50000 Hours
----------	----------------	-------------

## Dimensions

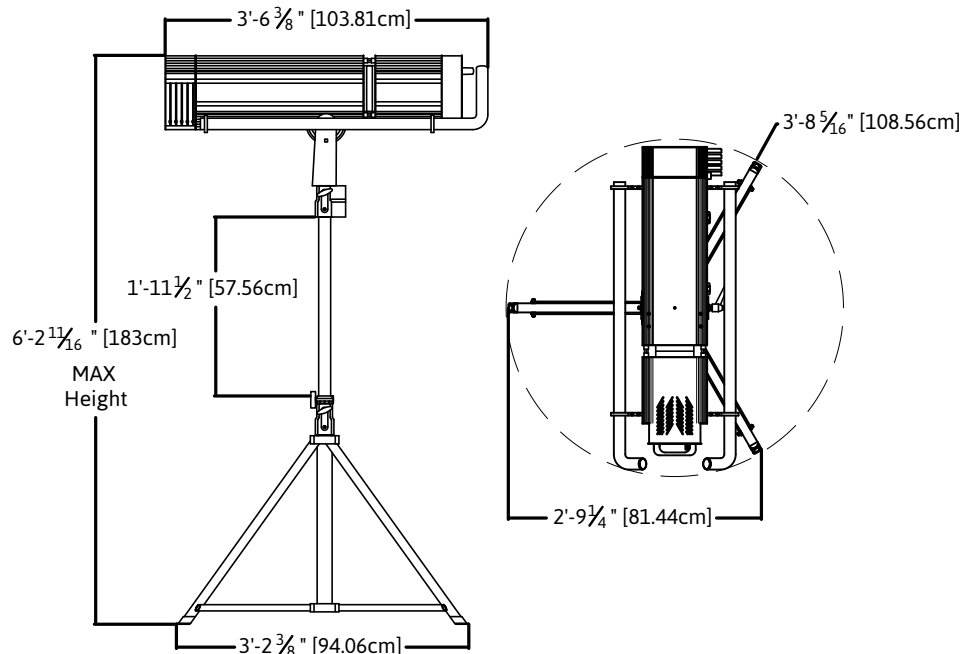

## Photometrics Foot Candles/Ft

<b>Red</b> 48.9fc	<b>Red</b> 12fc	<b>Red</b> 6.3fc
<b>Green</b> 128fc	<b>Green</b> 31.6fc	<b>Green</b> 14.8fc
<b>Blue</b> 28.5fc	<b>Blue</b> 8fc	<b>Blue</b> 4.4fc
<b>W27</b> 127fc	<b>W27</b> 30.9fc	<b>W27</b> 14.3fc
<b>W32</b> 237fc	<b>W32</b> 56.8fc	<b>W32</b> 26fc
<b>W56</b> 350fc	<b>W56</b> 82.7fc	<b>W56</b> 37.2fc

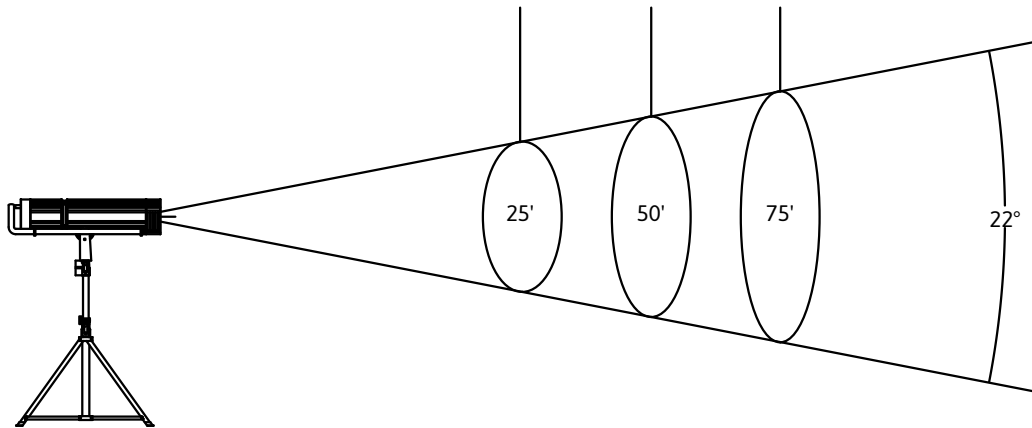

### Canto Astro 250 Wi-Fi

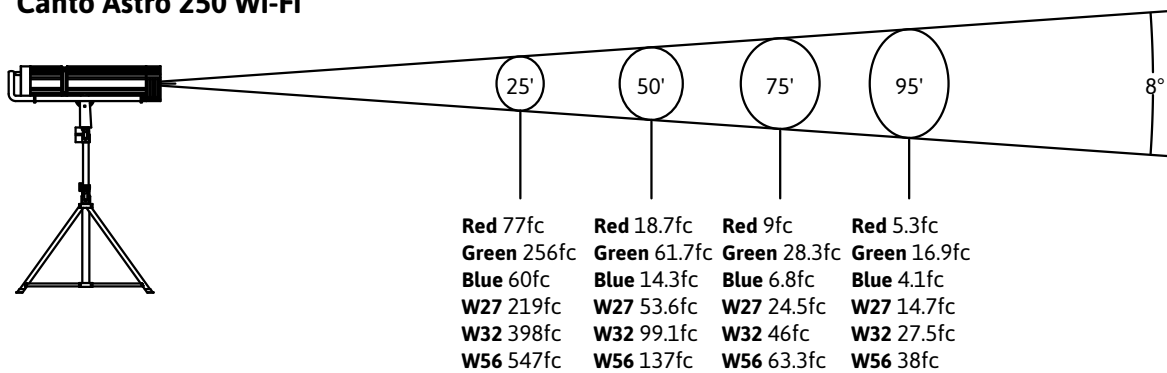

<b>Red</b> 77fc	<b>Red</b> 18.7fc	<b>Red</b> 9fc	<b>Red</b> 5.3fc
<b>Green</b> 256fc	<b>Green</b> 61.7fc	<b>Green</b> 28.3fc	<b>Green</b> 16.9fc
<b>Blue</b> 60fc	<b>Blue</b> 14.3fc	<b>Blue</b> 6.8fc	<b>Blue</b> 4.1fc
<b>W27</b> 219fc	<b>W27</b> 53.6fc	<b>W27</b> 24.5fc	<b>W27</b> 14.7fc
<b>W32</b> 398fc	<b>W32</b> 99.1fc	<b>W32</b> 46fc	<b>W32</b> 27.5fc
<b>W56</b> 547fc	<b>W56</b> 137fc	<b>W56</b> 63.3fc	<b>W56</b> 38fc

#### Foot Candle Wide Setting

Distance	25'	50'	75'
<b>Red</b>	48.9fc	12fc	6.3fc
<b>Green</b>	128fc	31.6fc	14.8fc
<b>Blue</b>	28.5fc	8fc	4.4fc
<b>White 2700K</b>	127fc	30.9fc	14.3fc
<b>White 3200K</b>	237fc	56.8fc	26fc
<b>White 5600K</b>	350fc	82.7fc	37.2fc

#### Foot Candle Narrow Setting

Distance	25'	50'	75'	95'
<b>Red</b>	77fc	18.7fc	9fc	5.3fc
<b>Green</b>	256fc	61.7fc	28.3fc	16.9fc
<b>Blue</b>	60fc	14.3fc	6.8fc	4.1fc
<b>White 2700K</b>	219fc	53.6fc	24.5fc	14.7fc
<b>White 3200K</b>	398fc	99.1fc	46fc	27.5fc
<b>White 5600K</b>	547fc	137fc	63.3fc	38fc

\* Photometrics are an average of 3 readings taken in a real world small theater application.

\* Light readings measured with a Sekonic C-700 U Spectromaster Color Meter.

\* Measurements were taken with a new fixture.