

**ALLEN&HEATH**

avantis

**Getting Started Guide**

**Avantis**

**i** Before starting please check [www.allen-heath.com](http://www.allen-heath.com) for the latest Avantis firmware and documentation.

AP11558 Issue 5

## **Limited One Year Manufacturer's Warranty**

Allen & Heath warrants the Allen & Heath -branded hardware product and accessories contained in the original packaging ("**Allen & Heath Product**") against defects in materials and workmanship when used in accordance with Allen & Heath's user manuals, technical specifications and other Allen & Heath product published guidelines for a period of ONE (1) YEAR from the date of original purchase by the end-user purchaser ("**Warranty Period**").

This warranty does not apply to any non-Allen & Heath branded hardware products or any software, even if packaged or sold with Allen & Heath hardware.

Please refer to the licensing agreement accompanying the software for details of your rights with respect to the use of software/firmware ("EULA").

Details of the EULA, warranty policy and other useful information can be found on the Allen & Heath website: [www.allen-heath.com/legal](http://www.allen-heath.com/legal).

Repair or replacement under the terms of the warranty does not provide right to extension or renewal of the warranty period. Repair or direct replacement of the product under the terms of this warranty may be fulfilled with functionally equivalent service exchange units.

This warranty is not transferable. This warranty will be the purchaser's sole and exclusive remedy and neither Allen & Heath nor its approved service centres shall be liable for any incidental or consequential damages or breach of any express or implied warranty of this product.

### **Conditions Of Warranty**

The equipment has not been subject to misuse either intended or accidental, neglect, or alteration other than as described in the User Guide or Service Manual, or approved by Allen & Heath. The warranty does not cover fader wear and tear.

Any necessary adjustment, alteration or repair has been carried out by an authorised Allen & Heath distributor or agent.

The defective unit is to be returned carriage prepaid to the place of purchase, an authorised Allen & Heath distributor or agent with proof of purchase. Please discuss this with the distributor or the agent before shipping. Units returned should be packed in the original carton to avoid transit damage.

**DISCLAIMER:** Allen & Heath shall not be liable for the loss of any saved/stored data in products that are either repaired or replaced.

Check with your Allen & Heath distributor or agent for any additional warranty information which may apply. If further assistance is required please contact Allen & Heath Ltd.

# IMPORTANT - Read before starting

## Safety instructions

Before starting, read the **Important Safety Instructions** printed on the sheet supplied with the equipment. For your own safety and that of the operator, technical crew and performers, follow all instructions and heed all warnings printed on the sheet and on the equipment panels.

## System operating firmware

The function of Avantis is determined by the firmware (operating software) that runs it. Firmware is updated regularly as new features are added and improvements made.

① Check [www.allen-heath.com](http://www.allen-heath.com) for the latest version of Avantis firmware.

## Software licence agreement

By using this Allen & Heath product and the software within it you agree to be bound by the terms of the relevant **End User Licence Agreement** (EULA), a copy of which can be found at [www.allen-heath.com/legal](http://www.allen-heath.com/legal). You agree to be bound by the terms of the EULA by installing, copying, or using the software.

## Further information

Please refer to the **Allen & Heath website** for further information, knowledgebase and technical support. For more information on Avantis setup and mixing functions please refer to the Avantis Firmware Reference Guide available for download at [www.allen-heath.com](http://www.allen-heath.com).

① Check for the latest version of this Getting Started Guide.

You can also join our Allen & Heath Digital Community to share knowledge and information with other Avantis users.

## General precautions

- Protect the equipment from damage through liquid or dust contamination. Cover the mixer when it is not being used for a long period.
- If the equipment has been stored in sub-zero temperatures allow time for it to reach normal operating temperature before use at the venue. Recommended operating temperature is 0 to 40 degrees Celsius.
- Avoid using the equipment in extreme heat and direct sunlight. Make sure the ventilation slots and fans underneath the unit are not obstructed and that there is adequate air movement around the equipment.
- Clean the equipment with a soft brush and dry lint-free cloth. Do not use chemicals, abrasives or solvents. Do not use lubricant or contact cleaner on the faders.
- It is recommended that servicing is carried out only by an authorised Allen & Heath agent. Contact details for your local distributor can be found on the Allen & Heath website. Allen & Heath do not accept liability for damage caused by maintenance, repair or modification by unauthorised personnel.
- To prevent damage to the controls and cosmetics, avoid placing heavy objects on the mixer, scratching the mixer or touchscreen with sharp objects, or rough handling and vibration.

## Register your product

Register your product online at [www.allen-heath.com/register](http://www.allen-heath.com/register).

# Packed items

Check you have received the following:

- Avantis Digital Mixing Console
- Getting Started Guide AP11558
- Safety Sheet
- IEC mains lead

# Contents

IMPORTANT - Read before starting .....	3
Safety instructions .....	3
System operating firmware .....	3
Software licence agreement .....	3
Further information .....	3
General precautions .....	3
Register your product .....	3
Packed items .....	4
Contents .....	4
1. Introduction .....	5
2. Connect and power up .....	6
2.1 Power Up .....	6
2.2 Calibrate Touch Faders .....	6
2.3 Recall a Template Show .....	6
2.4 Expander Connection .....	6
2.5 Power Down .....	6
3. dPack Activation .....	7
4. Rear Panel .....	8
5. Front Panel .....	9
6. Top Panel .....	10
6.1 Fader strip .....	11
6.2 Screens .....	12
7. Mix Basics .....	13
7.1 Working with the Main Mix .....	13
7.2 Working with Sends – Master Mix Mode .....	14
7.3 Working with Sends – Channel Mix Mode .....	14
7.4 Assigning and un-assigning a channel to a Mix, Group or DCA .....	15
7.5 Changing between Sends on Faders and Sends on Rotaries .....	15
7.6 Setting Pre/Post fader send status .....	15
8. Dimensions .....	16
9. Flightcase Information .....	17
10. Expanders, I/O Cards and Controllers .....	18
10.1 Expanders .....	18
10.2 I/O Cards .....	18
10.3 Remote Controllers .....	18
10.4 Personal Monitor Mixing .....	18
11. Technical Specifications .....	19

# 1. Introduction

Avantis is a 64 channel 96kHz digital mixing console providing a powerful solution for any live sound application. Pristine audio quality is delivered at ultra-low latency, and comprehensive signal routing and processing options are easily accessible via the dual 15.6" Full HD touchscreens.

Avantis is DEEP Processing ready, enabling the use of our world-class hardware emulations with no added latency or need for additional hardware. Visit [allen-heath.com/avantis](http://allen-heath.com/avantis) for more information.

The integrated SLink port offers Plug'n'Play operation with the GX, DX, AB and AR ranges of remote I/O expanders plus the DX Hub remote hub. Additionally, SLink can be used for digital split applications with a second Avantis mixer or a dLive/SQ system.

Compatibility with the ME Personal Monitoring System allows performers to take control of their own monitor mixes via the ME-1 and ME-500 personal mixers.

Digital audio networking cards are available to enable integration with other digital audio systems via protocols such as gigaACE, Dante, MAD1 and Waves SoundGrid.

Avantis features at a glance:

- **XCVI** FPGA core
- 96kHz sample rate, 96bit accumulator
- Ultra-low latency (0.7ms)
- 64 Input Channels with full processing (filter, gate, PEQ, compressor, inserts)
- 42 configurable Mix outputs
- **DEEP Processing** - embedded channel plugins
- 12 RackFX with dedicated returns
- 16 DCAs
- Twin 15.6" Full HD capacitive touchscreens
- Fully assignable layout
- 144 fader strips (24 faders, 6 layers) with optional dedicated master section
- **SLink** port for connection to Remote I/O Expanders and the ME Personal Monitoring System
- 12 analogue XLR Inputs / 12 analogue XLR Outputs
- 1 Stereo AES In / 2 Stereo AES Out
- 2 I/O Ports, both capable of 128x128 operation at 96kHz
- Gesture control – pinch, swipe, drag 'n drop
- User configurable rotary controls
- 24 assignable SoftKeys
- Comprehensive multipoint metering with peak detection
- USB stereo recording and playback
- BNC Word Clock

Refer to the Allen & Heath website to learn more about Avantis.

## 2. Connect and power up

### 2.1 Power Up

Ensure the rocker switch is in the off position. Plug in the IEC mains power lead supplied with the mixer. If required, secure the lead by hooking it into the plastic clip using a T20 Torx to remove the fixing screw. Power on the mixer using the rocker switch.

### 2.2 Calibrate Touch Faders

On first use, calibrate the fader touch sensitivity by going to **Utility / Utility / Calibration** and select **Calibrate Fader Touch**, select **Left Bank** and **All** and follow the onscreen instructions ensuring you only touch the first fader in the bank when instructed.

Once completed, repeat this process for the **Right Bank**, ensuring you only touch the first fader in the bank when instructed.

### 2.3 Recall a Template Show

Avantis has a fully configurable audio architecture, control layout, and socket patching. We have provided a set of Template Shows to give a choice of classic console formats to load as a quick starting point with a familiar architecture and logical layout.

To load a Template Show go to the **Utility / Memory / Show Manager** screen, select one of the available Template Shows, touch **Recall** and confirm.

- ① Recalling a Show overwrites all the system settings including the bus configuration, control layout, current parameters, all Scenes, and Library presets. If you want to save the current settings then first **Store** them as a User Show.
- ① For more information please refer to the Avantis Firmware Reference Guide available for download at [www.allen-heath.com](http://www.allen-heath.com).

### 2.4 Expander Connection

Plug a touring grade CAT5e (or higher specification) cable up to 100m long between the Remote Expander and SLink port.

- ① Refer to [www.allen-heath.com](http://www.allen-heath.com) for cable requirements, recommendations, and a list of CAT5 cables available to order.

Switch on the Remote Expander. The SLink port Lnk/Err indicators flash at a steady rate when the link is established. The red error indicator lights if a communication error is detected. Check that the cables are the correct type, plugged in correctly, and are not faulty.

The following Remote Expanders are compatible with the Avantis SLink port:

Remote Expander	Sample Rate	Protocol
GX4816	96kHz	GX
DX32, DX168, DX164-W, DX012, DX Hub	96kHz	DX
AR2412, AR84	48kHz	dSnake
AB168	48kHz	dSnake

- ① For more information on our range of I/O expanders please visit [www.allen-heath.com/everything-io/](http://www.allen-heath.com/everything-io/)

### 2.5 Power Down

The system must be powered down correctly. Navigate to **Utility / Status / Homescreen** and touch the Power Down button. Confirm the action and then turn the mixer and expanders off using their power switches.

- ① If the system is not powered down correctly there is a possibility recent changes may be lost.
- ① If the system was not powered down as described above, then a “Not Shut Down Correctly” screen appears the next time the system is turned on.

### 3. dPack Activation

Upgrade your console with Avantis dPack to access additional dLive processing including Dyn8 (up to 16 instances), DEEP Compressors and the Dual Stage Valve Preamp, plus more models as they're added.

If you purchased your Avantis with the dPack upgrade, you should have received a 12-character voucher code. To redeem your dPack voucher code and activate your upgrade:

1. Visit [allen-heath.com/avantis](http://allen-heath.com/avantis) and ensure you have downloaded and installed the latest firmware on your Avantis
2. Go to [shop.allen-heath.com](http://shop.allen-heath.com), select the Avantis dPack product and add it to your Shopping Cart.
3. Click on 'Shopping Cart' in the top right menu bar
4. Click on 'Use Coupon Code' and enter your code as supplied – then click 'Apply Coupon'
5. Click 'Checkout' and complete the checkout process.
6. Once you've completed checkout, go to your Account Downloads page – My Account > Downloads
7. Follow the instructions on screen to generate your dPack upgrade key and enter it in to your console.

If you did not purchase your Avantis with the dPack upgrade, but wish to purchase dPack for your mixer, please visit [shop.allen-heath.com](http://shop.allen-heath.com)

If you experience any difficulties, please contact Allen & Heath Shop Support by emailing [shopsupport@allen-heath.com](mailto:shopsupport@allen-heath.com)

## 4. Rear Panel

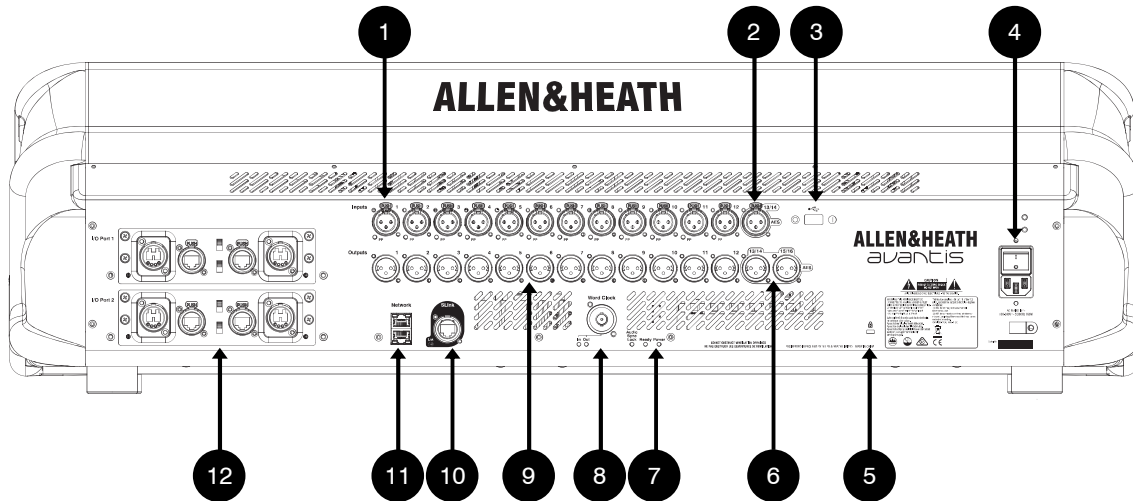

### 1. Mic/Line Inputs

12x recallable preamps for balanced or unbalanced microphone and line level signals. Gain, Pad and 48V are digitally controlled within the preamp. The PP indicator lights up when phantom power voltage is detected at the socket, whether internally or externally sourced.

Any socket can be patched to any Input Channel using the **I/O** or **Processing / Preamp** screen.

### 2. Digital Inputs

Stereo AES3 input (32kHz – 192kHz sampling rate). Sample Rate Conversion can be bypassed.

Any socket can be patched to any Input Channel using the **I/O** or **Processing / Preamp** screen.

### 3. USB 2.0 Socket

Insert a compatible USB device to store and recall show files, update the firmware or to perform USB playback and recording.

### 4. Power Supply

Mains IEC socket, fuse and On/Off rocker switch. A plastic P-clip cable clamp is provided to secure the mains cable. Slot the cable in, or lock it in place using a star Torx® T20 screwdriver to refit the clamp around the cable.

 Heed the safety warnings printed on the panel.

### 5. Kensington Lock

A slot for fitting standard Kensington anti-theft security devices.

### 6. Digital Outputs

Stereo AES3 outputs (44.1kHz, 48kHz or 96kHz switchable). Signals can be patched to any output socket using the **I/O** screen.

### 7. Status Indicators

Power ON indicator. The Ready indicator illuminates when the output sockets are ready to pass audio after power up. The Audio Sync Locked indicator illuminates when a valid clock source is present.

### 8. Word Clock I/O

BNC connector for syncing from an external audio clock or providing a clock to other devices. In and Out LEDs indicate the current mode.



## 9. Line Outputs

12x line level, balanced XLR outputs. Nominal level +4dBu. The outputs are relay protected to prevent power on or off thumps. Signals can be patched to any output socket using the I/O screen.

## 10. SLink

For connection to remote I/O expanders and/or the ME Personal Monitoring System. See the Expander Connection section of this document for more information on supported devices.

## 11. Network

2 RJ45 Gigabit Ethernet ports. Connect a laptop or a wireless router to use with Avantis Editor or iOS apps. All devices on the network must have compatible IP addresses.

The default settings are:

<b>DHCP Enabled:</b>	Off
<b>IP Address:</b>	192.168.1.80
<b>Subnet Mask:</b>	255.255.255.0
<b>Gateway:</b>	192.168.1.254

## 12. I/O Ports

2 Audio interface ports, both capable of 128x128 channels. Fit one of the option cards available for system expansion, digital mic splitting, recording or distributed audio networking. Refer to [www.allen-heath.com](http://www.allen-heath.com) for a list of available option cards. Use the I/O screen to patch signals from or to the I/O Ports.

# 5. Front Panel

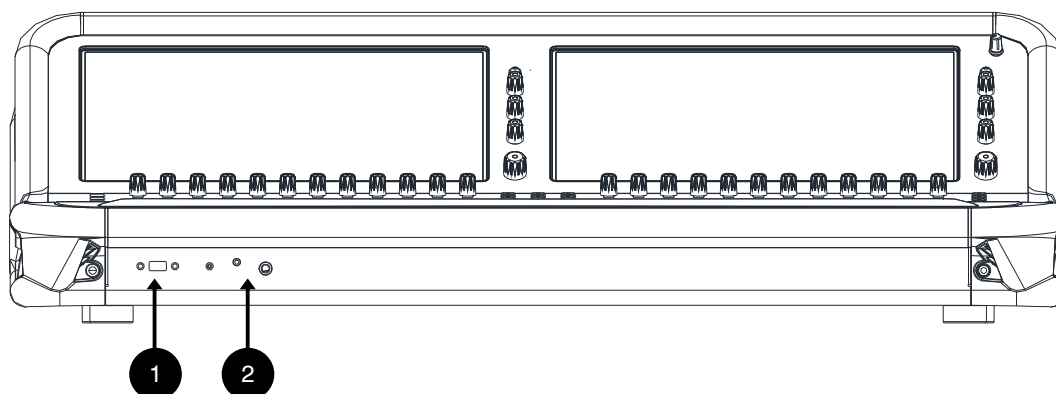

### 1. USB 3.0 Socket

Insert a compatible USB device to store and recall show files, update the firmware or to perform USB playback and recording.

### 2. Headphone Sockets

Standard 1/4 " and 1/8" headphone jack sockets are located under the armrest.

## 6. Top Panel

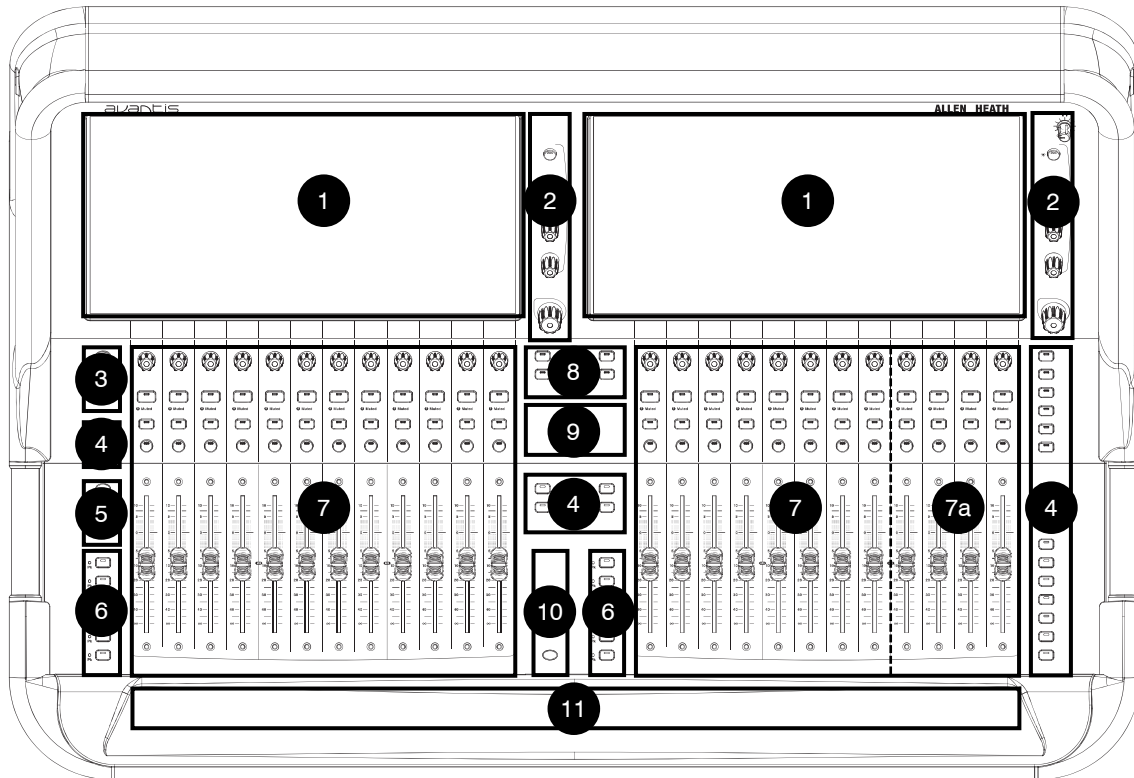

### 1. Touchscreens

15.6" capacitive touchscreens. See the Screens section for more information.

### 2. Screen Controls

Control of user-assignable parameters. See the Screens section for more information.

### 3. Pre / Safes / Freeze

Toggle channel status:

- **Pre/Post** - Hold down **Pre**, and touch a channel **Name Block** to toggle the sends to the active Mix between pre or post fade. Toggle all channels pre/post by touching a master mix **Name Block**. Assignments and pre/post settings for the selected channel or Mix are also available in the **Routing** screen.
- **Safes** - Hold down **Safes** and press a **Name Block** to make the channel safe from Scene recall. To make only a selection of parameters safe, use the **Scenes / Global Safes** screen.
- **Freeze in Layers** - Hold down **Freeze in Layers** and press a **Name Block** to lock a channel in place across all layers.

### 4. SoftKeys

24 user-assignable keys. Assign functions using the **Setup / Control / SoftKeys** screen.

### 5. Copy / Paste / Reset

- **Copy** – Hold down **Copy** and press:
  - A channel **Name Block** to copy the entire channel processing.
  - Any highlighted area of the touchscreen to copy the settings of a single **Processing Block**.
  - A strip **Mix** key to copy the mix assignments and send levels.
- **Paste** - Hold down **Paste** and press a **Name Block**, **Mix** key or a highlighted area of the touchscreen to paste copied settings.
- **Reset** - Hold down **Reset** and press a **Name Block**, **Mix** key or a highlighted area of the touchscreen to reset the related parameters to factory default. Hold down **Reset** and nudge a fader up or down to quickly set it to 0dB or off.

## 6. Layers

Navigate 6 layers of fader strips per bank. The red Pk (peak) indicators illuminate when any channel in the associated layer is within 3dB of clipping, so you can monitor signal activity across the layers. Banks can be linked using the **Setup / Control / Surface Prefs** screen – the Layer keys will affect both Banks when Link is active.

## 7. Fader Banks

Two 12 channel fader banks provide control of Input channels, FX returns, Mix masters, DCAs, engineer's Wedge / IEM monitor, or MIDI. Read the Fader Strip section below for further information. A dedicated master section (**7a**) can be enabled for persistent visibility of 4 channel strips. The strip layout is user assignable and stored in Scenes. Use the **Setup / Control / Strip Assign** screen to edit the strip layout and enable the master section.

## 8. Strip Rotary Mode

Select the function of the fader strip rotary encoders. The fader strip rotaries can control preamp Gain, Pan, Sends to the active Mix, and 3 assignable functions. Assign these using the **Setup / Control / Preferences** screen. The colour of the rotary LED matches the active function e.g. red for Gain, yellow for Pan; it follows the colour of the active Mix when in Sends mode. The **Sends** function puts control of send levels to the active Mix on the strip rotaries, while the faders control the channel levels to the main mix (i.e. it temporarily disables 'sends on faders')

## 9. Assign

Hold down **Assign**, and press a strip **Mix** key to toggle routing assignment on or off. See later in this guide for more information.

## 10. GEQ on Faders

Touch and hold **GEQ**, and touch a mix channel **Name Block** to present the GEQ on the faders. Frequency values are shown on the **Name Blocks** and the meters show RTA activity of each frequency band and peak band indication. While active, touch **GEQ** again to toggle between high and low frequencies. The mix master fader is presented on the right-hand strip while in this mode.

## 11. Armrest Illumination

Change illumination settings in **Setup / Control / Dimmer**.

### 6.1 Fader strip



**Strip Rotaries** – Their function is selected using the strip rotary mode keys described earlier in this chapter. The rotaries can control preamp Gain/Trim, Pan, Sends to the active Mix, and 3 user-assignable functions. The colour of the rotary LED matches the active function e.g. red for Gain, yellow for Pan; it follows the colour of the active Mix when in Sends mode. The value is displayed in the Name Block display



**Mute** – Turns off the channel signal. Affects the main mix, pre-fade and post-fade sends. The switch illuminates when the signal is muted.



**Muted** – Illuminates when the channel is muted by a DCA or Mute Group.



**Mix** – Puts the send levels and assignments of the associated channel or masters onto the fader strips (or strip rotaries when rotaries are in Sends mode).

**i** The currently active Mix is displayed in the top right corner of the Processing screen. Press an active **Mix** key to return to the main mix.



**PAFL** – Sends the channel signal PFL (pre-fade listen) or AFL (after-fade listen) to the headphones and monitoring system. Preferences for the PAFL system are set using the **Setup / Audio / PAFL** screen.

## 6.2 Screens

Avantis has two screens, both showing channel processing, bank overview, system setup & status, memory management menus and more.

Each touchscreen integrates with a trio of user-configurable soft rotaries in addition to a Touch & Turn rotary control for quick and easy parameter modification.

Both screens operate independently of each other so, for example, two discrete channel processing screens can be visible simultaneously, or processing can be visible on one screen with IO patching visible on the other.

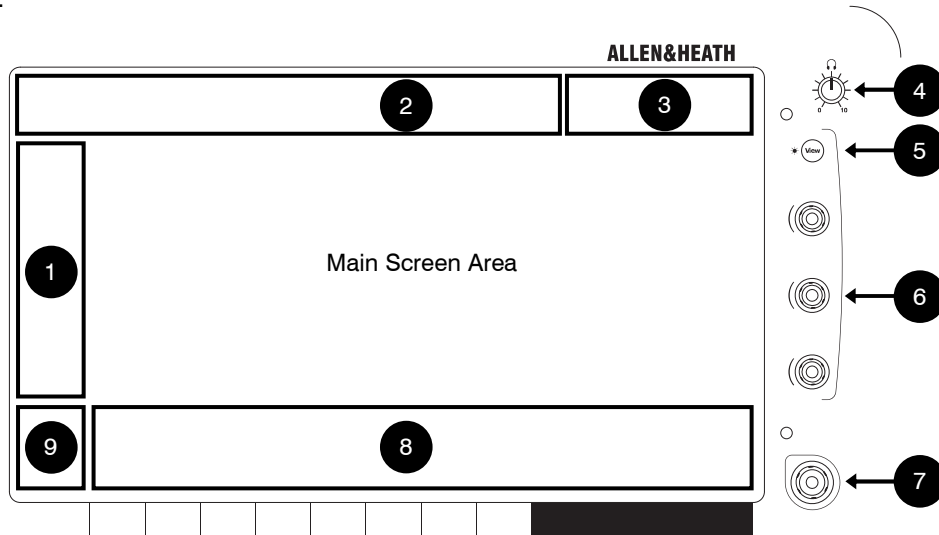

### 1. Screen Mode

Select the Screen Mode:

- **Bank** – Overview of all channels assigned to the fader Bank and Layer. Bank view can be used with the **Copy, Paste, Reset, Freeze** and **Listen** keys. In Bank view, touching any processing block – for example, a PEQ, Gate or Comp curve – opens the relevant **Processing** page.
- **Processing** – Access channel processing for the currently selected channel
- **Routing** – Access routing and assignments for the selected channel
- **I/O** – Patch system inputs and outputs by tapping on crosspoints
- **Ganging** – Create up to 16 gang groups to link selected parameters across multiple channels
- **Meters** – Access to Input, FX and Mix meters, RTA spectrogram and 4 user-customisable meter views.
- **FX** – Configure the 12 RackFX units.
- **Scenes** – Access to the Scene Manager, Global Safes and other scene tools
- **Setup** – Access to mixer strip layout, mixer bus configuration, softkey configuration, stereo input configuration, network settings, audio settings, user profiles, mixer preferences, illumination and more.
- **Utility** – Access the Show Manager, Library Manager, firmware update, system diagnostics, fader, and screen calibration, and MIDI options.

### 2. Menu Tabs

Menu options for the selected Screen Mode.

### 3. Status Bar

Icons are visible when certain modes of operation are active (Virtual Soundcheck, Solo In Place, Scene Update Auto Tracking, etc) or if a system error is logged.

### 4. Headphone Volume

Rotary volume control for the headphone output (right-hand side only)

### 5. View

Press to toggle between the configured views for the Soft Rotaries.

### 6. Soft Rotaries

Three soft rotaries for the control of user-assignable parameters.

## 7. Touch & Turn Control

Touch a parameter or setting in the main screen area and adjust its value with the rotary control. The currently selected parameter is highlighted in orange.

## 8. Name Block

Displays name, colour, channel type, number, metering information, and other channel parameters.

Touch a channel **Name Block** to select a channel for use with the Processing and Routing screens. When selected, the channel strip will be shaded green.

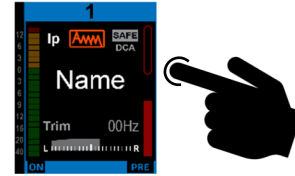

Each bank can have one channel selected. The currently selected channel is displayed in the top left corner of the screen.

## 9. Swipe Menu / Meters

Multi-page menu showing either PAFL meters or additional contextual options. Swipe the menu, or touch the circular page indicators, to scroll between the pages.

- **Listen** – Hold down **Listen** and touch any highlighted area of the screen to listen to that point in the signal path of the selected channel
- **Options** – Hold down **Options** and touch any highlighted area of the screen to configure it.
- **Name / dB / IO** – Tap to toggle between Name Block modes to display the user-defined channel **Name**, the fader position in **dB**, or the I/O socket identifier of the patched source/destination.
- **Help** – Touch to display contextual help for the active screen
- **PAFL Meter**

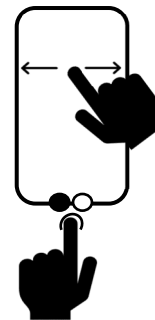

# 7. Mix Basics

## 7.1 Working with the Main Mix

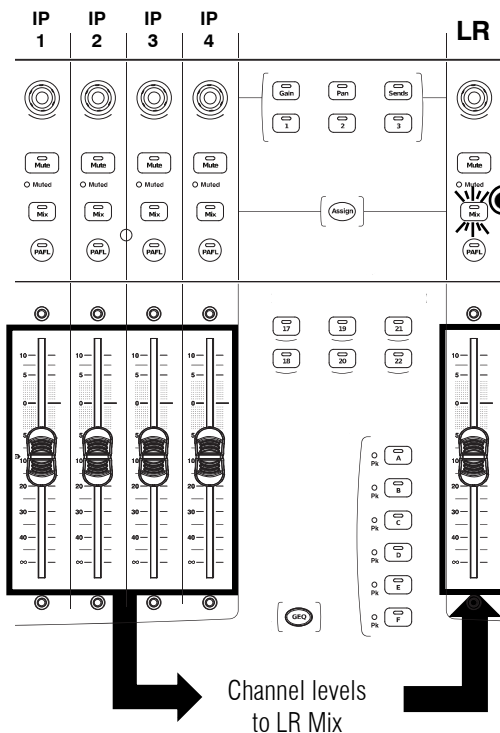

Press a Main Mix (e.g. LR) master strip **Mix** key.

This is the default mixing mode:

The Input strips present the channel faders. The Master strips present the master mix faders.

Channel levels to LR Mix

## 7.2 Working with Sends – Master Mix Mode

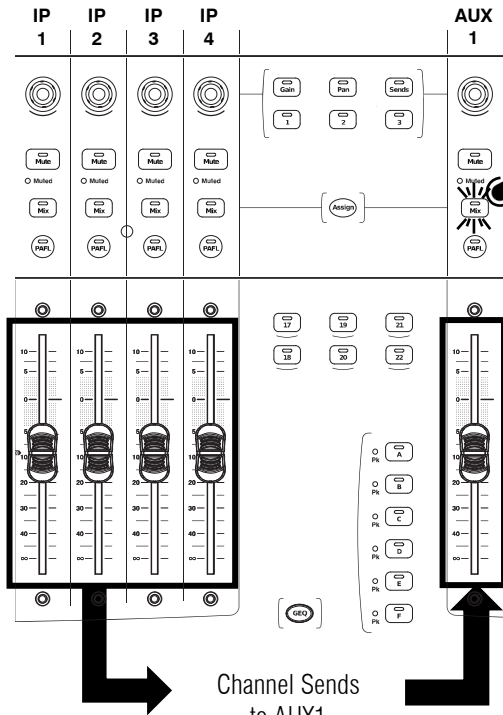

Press a Mix master strip **Mix** key (e.g. AUX 1)

Use this to work with Aux and FX sends.

The Input strips present all the send levels to the active Mix.

The Master strips present the master mix faders.

## 7.3 Working with Sends – Channel Mix Mode

Press an Input Channel strip **Mix** key (e.g. IP 1)

Use this to work with Aux and FX sends.

The Input strips remain as Channel Faders.

The Master strips present all sends from the Input channel.

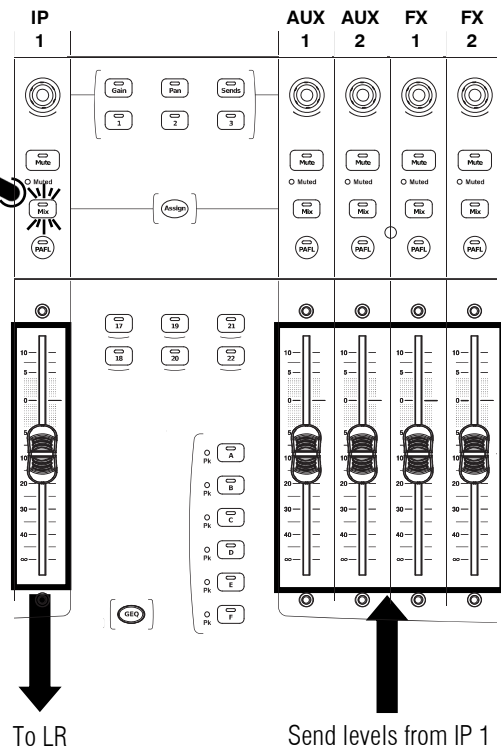

## 7.4 Assigning and un-assigning a channel to a Mix, Group or DCA

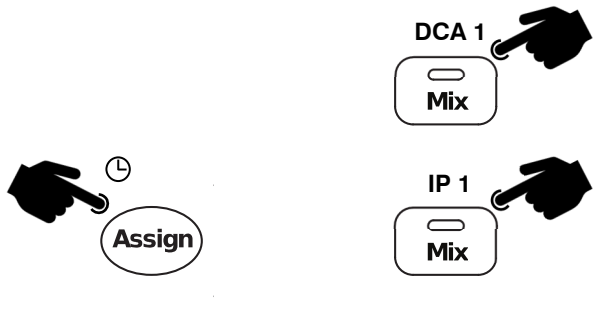

The diagram shows a hand pointing to a button labeled 'Assign' with a clock icon. To the right, there are two 'Mix' buttons. The top one is labeled 'DCA 1' and the bottom one is labeled 'IP 1'. A hand is shown pointing to the 'Mix' button for 'IP 1'.

Press the **Mix** key on a Mix, Group or DCA master strip (e.g. DCA 1)

Hold down the **Assign** key and press channel **Mix** keys to assign or unassign them from the active mix. Assignment status is displayed in the Name Block.

You can quickly set **all** assignments to a Mix to On or Off by pressing the **Mix** button on a Mix Master, and then pressing and holding the **Assign** button while pressing the **Mix** button the Mix Master.

## 7.5 Changing between Sends on Faders and Sends on Rotaries

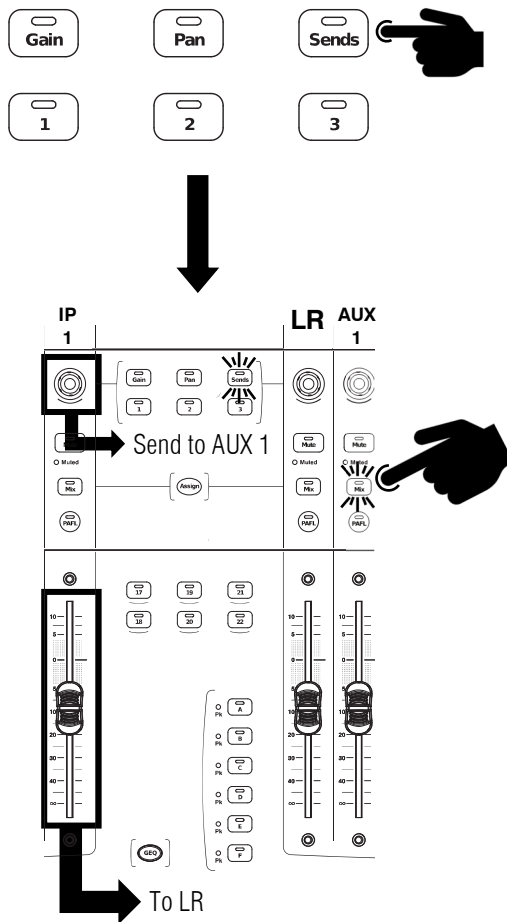

The diagram shows three buttons: 'Gain', 'Pan', and 'Sends'. A hand is pointing to the 'Sends' button. Below these are three buttons labeled '1', '2', and '3'. A large downward arrow points to a detailed view of a channel strip. The channel strip has two sections: 'IP 1' and 'LR AUX 1'. In the 'IP 1' section, a hand is pointing to a rotary knob labeled 'Send to AUX 1'. In the 'LR AUX 1' section, a hand is pointing to a rotary knob. Below the channel strip, there are two faders. An arrow points from the 'IP 1' section to the left fader, and another arrow points from the 'LR AUX 1' section to the right fader, labeled 'To LR'.

The default mixing mode is Sends on Faders.

To activate Sends on Rotaries, press the **Sends** button in the Strip Rotary Mode section.

In Sends on Rotaries mode, Strip Rotaries are used to control send levels to the active mix, with the channel faders remaining as level controls to the Main Mix.

## 7.6 Setting Pre/Post fader send status

Hold down the **Pre** key and touch channel **Name Blocks** to toggle each source pre or post fader. Current Pre/Post status is displayed on the lower part of the Name Block.



You can quickly set **all** assignments pre or post fader by touching the Mix Master **Name Block** while holding **Pre**.

# 8. Dimensions

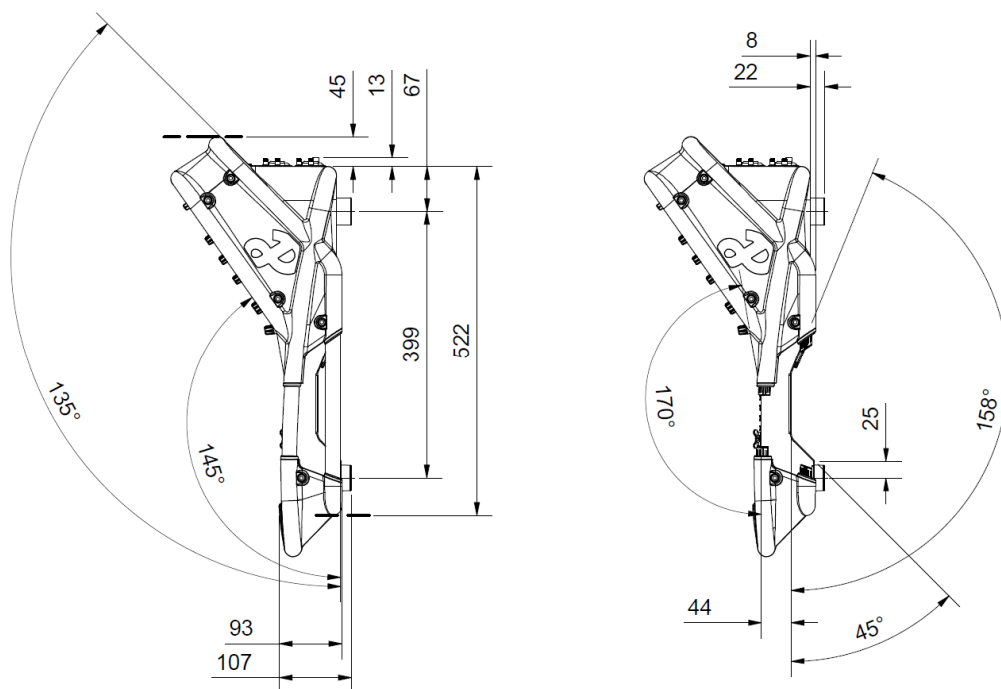
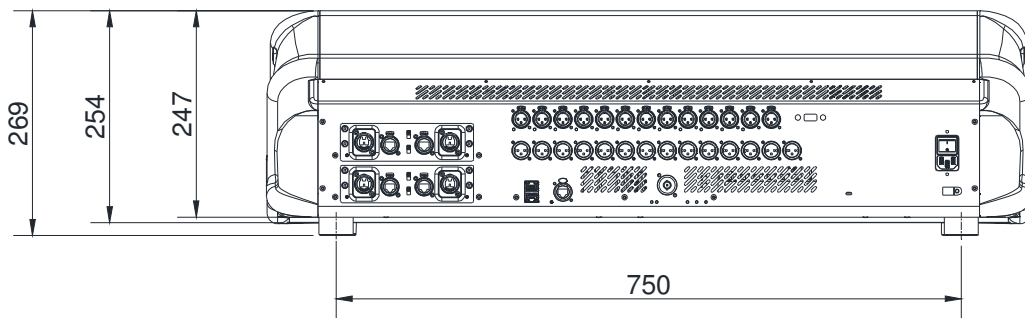
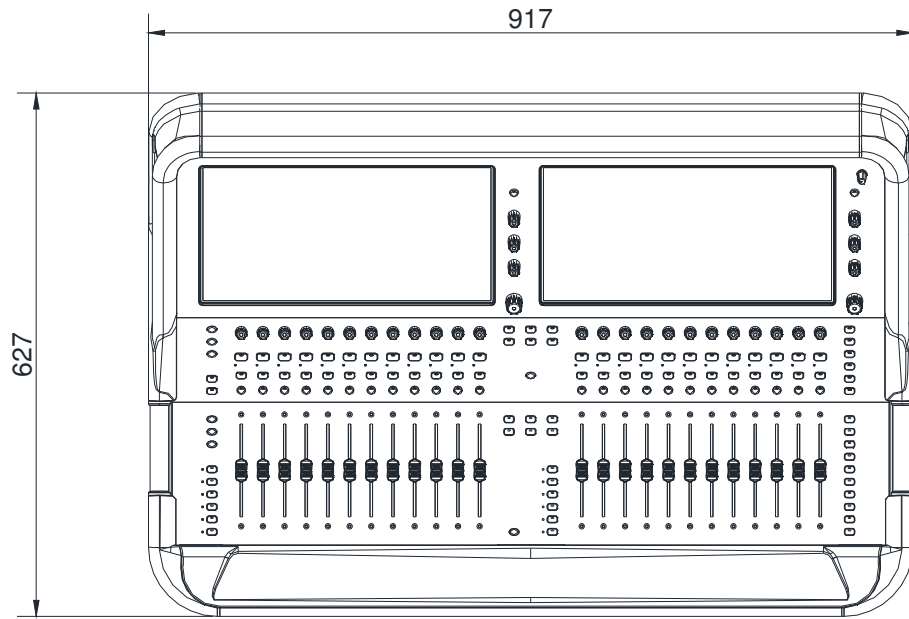



## 9. Flightcase Information

Do not remove the 4 rubber feet from the mixer.

Leave adequate space for ventilation (↻) and connections at the front, rear, and sides of the mixer.

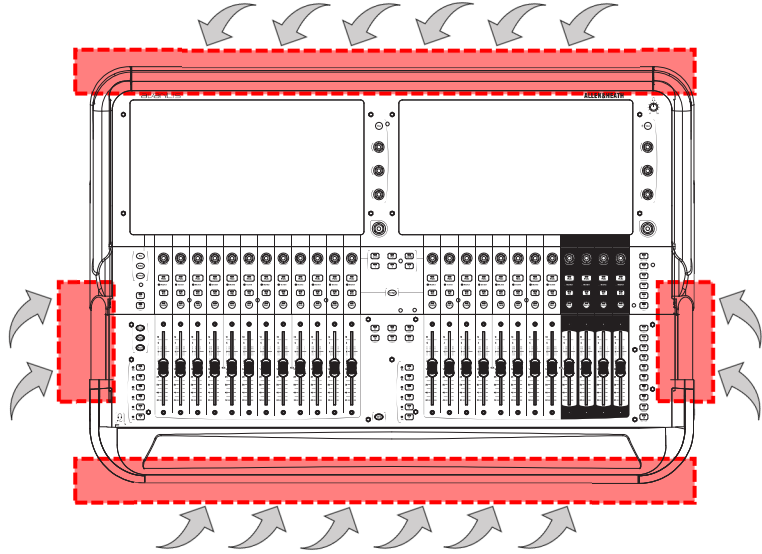

Leave adequate space for ventilation (↻) at the sides of the mixer in the area indicated.

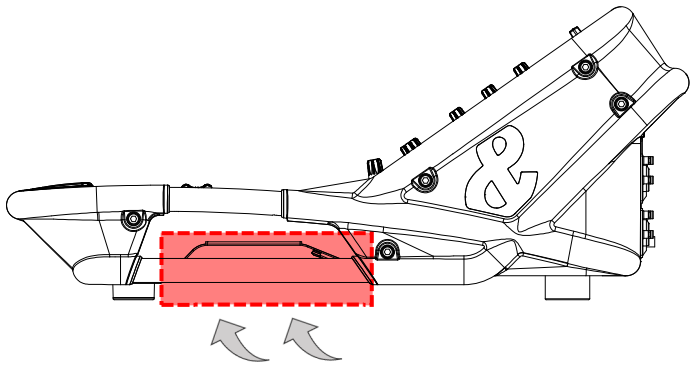

Leave adequate space for (1) ventilation (↻) and (2) USB / headphone connections at front of mixer.

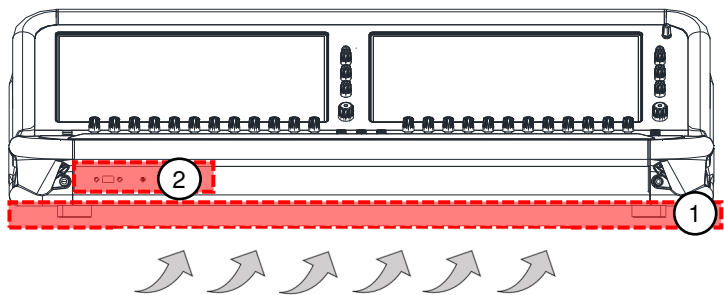

Leave adequate space for (1) ventilation (↻) and (2) audio / power connections at rear of mixer.



## 10. Expanders, I/O Cards and Controllers

Avantis is compatible with a wide range of expanders, I/O cards, personal monitor mixers and remote controllers. Please visit the Allen & Heath website, or contact your local distributor, for more information.

### 10.1 Expanders

	Sample Rate	Inputs	Outputs	Connection
<b>GX4816</b>	96kHz	48	16	SLink port, gigaACE card
<b>DX32</b>	96kHz	Up to 32		SLink port, DX Link, DX Hub
<b>DX168</b>	96kHz	16	8	SLink port, DX Link, DX Hub
<b>DX164-W</b>	96kHz	16	4	SLink port, DX Link, DX Hub
<b>DX012</b>	96kHz	0	12	SLink port, DX Link, DX Hub
<b>DT168</b>	96kHz/48kHz	16	8	Dante card
<b>DT164-W</b>	96kHz/48kHz	16	4	Dante Card
<b>DX Hub</b>	96kHz	128	128	SLink port, gigaACE card
<b>AR2412</b>	48kHz	24	12	SLink port
<b>AR84</b>	48kHz	8	4	Slink port
<b>AB168</b>	48kHz	16	8	Slink port

Visit [allen-heath.com/everything-io/](http://allen-heath.com/everything-io/) for more information on our range of expansion options.

### 10.2 I/O Cards

<b>Dante 64x64</b>	64x64	96kHz/48kHz	Dante audio networking card
<b>Dante 128x128</b>	128x128	96kHz/48kHz	Dante audio networking card
<b>gigaACE</b>	128x128	96kHz	dLive/Avantis point-to-point connections
<b>fibreACE</b>	128x128	96kHz	gigaACE via multimode fibre optic
<b>DX Link</b>	128x128	96kHz	DX expander interface
<b>Waves3</b>	128x128	96kHz/48kHz	Waves SoundGrid audio networking card
<b>superMADI</b>	128x128	96kHz/48kHz	Optical and coaxial MADI interfacing
<b>AES 4i6o</b>	4x6	96/88/48/44.1kHz	4 in, 6 out, AES3 audio interface
<b>AES 10o</b>	0x10	96/88/48/44.1kHz	0 in, 10 out, AES3 audio interface
<b>AES 6i4o</b>	6x4	96/88/48/44.1kHz	6 in, 4 out, AES3 audio interface
<b>AES 2i8o</b>	2x8	96/88/48/44.1kHz	2 in, 8 out, AES3 audio interface

### 10.3 Remote Controllers

<b>IP1</b>	Wallmount remote controller with 1 dual-function rotary encoder
<b>IP6</b>	Remote controller with 6 push-and-turn rotary encoders
<b>IP8</b>	Remote controller with 8 motorised faders
<b>GPIO</b>	General purpose I/O interface for remote control

### 10.4 Personal Monitor Mixing

<b>ME-500</b>	16 Channel Personal Mixer
<b>ME-1</b>	40 Source Personal Mixer
<b>ME-U</b>	Personal Monitor Mixer Hub

Visit [allen-heath.com/me/](http://allen-heath.com/me/) for more information.

# 11. Technical Specifications

## Inputs

<b>Mic/Line XLR Inputs</b>	Balanced XLR, +48V phantom power
Mic/Line Preamp	Fully recallable
Input Sensitivity	-60 to +15dBu
Analogue Gain	+5 to +60dB, 1dB steps
Pad	-20dB Active PAD
Maximum Input Level	+30dBu (PAD in)
Input Impedance	>4k $\Omega$ (Pad out), >10k $\Omega$ (Pad in)
Mic EIN	-127dB with 150 $\Omega$ source
Phantom Power indication	Per socket, internal or external phantom power sensing, triggered at +24V
<b>Digital Inputs</b>	AES3 2 Ch XLR, 2.5Vpp balanced terminated 110 $\Omega$  SRC range 24 bit, 32k - 192kHz, with bypass option

## Outputs

<b>Analogue XLR Outputs</b>	Balanced, Relay protected
Output Impedance	<75 $\Omega$
Nominal Output	+4dBu = 0dB meter reading
Maximum Output Level	+22dBu
Residual Output Noise	-95dBu (muted, 22-22kHz)  -90dBu (muted, 0-80kHz)
<b>Digital Outputs</b>	AES3 2 Ch XLR, 2.5Vpp balanced terminated 110 $\Omega$  96kHz sampling rate, globally switchable to 48kHz, 44.1kHz

## System

Measured balanced XLR In to XLR Out, 22-40kHz, minimum Gain, Pad out	
Dynamic Range	109dB
System Signal to Noise	-92dB
Frequency Response	20Hz - 30kHz (+0/-0.8dB)
THD+N (analogue in to out)	0.0015% @ +16dBu output, 1kHz 0dB gain
Headroom	+18dB
Internal operating Level	0dBu
dBFS Alignment	+18dBu = 0dBFS (+22dBu at XLR output)
Meter Calibration	0dB meter = -18dBFS (+4dBu at XLR out)
Meter Peak indication	-3dBFS (+19dBu at XLR out)
Sampling Rate	96kHz
Operating Temperature Range	0 deg C to 40 deg C 32 deg F to 104 deg F
Mains Power	100-240V AC, 50-60Hz, 150W max
USB Audio playback	Mono/stereo .WAV files, (16/24bit, 44.1/48/96kHz) MP3 files FLAC files
USB Audio recording	Stereo .WAV files, (24bit 96kHz)

## Dimensions and Weights

	Unboxed		Boxed
<b>Width x Depth x Height</b>	917 x 627 x 269 mm 36.1" x 24.7" x 10.6"	<b>Width x Depth x Height</b>	1100 x 850 x 425 mm 43.3" x 33.5" x 16.7"
<b>Weight</b>	26kg 57.4lbs	<b>Weight</b>	34kg 75lbs

# **ALLEN&HEATH**

## Avantis Getting Started Guide

Copyright © 2019 Allen & Heath. All rights reserved.

Allen & Heath Limited, Kernick Industrial Estate, Penryn, Cornwall, TR10 9LU, UK

[www.allen-heath.com](http://www.allen-heath.com)