

GENERAL INFORMATION

The ArcSystem Recessed Ceiling Bracket allows any ArcSystem Pro One-Cell recessed luminaire to be securely installed into a suspended/drop ceiling grid. The bracket also doubles up as a convenient mounting mechanism between ceiling joists for new construction projects.

The easy-to-install bracket extends the range of applications of the Pro One-Cell fixture line. Featuring a unique 'reach and click' assembly that allows an ArcSystem D1 driver to be secured with one hand, as well as extendable arms that allow it to attach to ceiling joists or clip to a ceiling grid.

Note: ArcSystem fixture sold separately

APPLICATIONS

- Suspended/Drop Ceilings
- New Construction
- Suitable for use between joists or T-bar grids with a spacing of 12 inches (30.5cm) to 24 inches (61cm)

FEATURES

- Sliding, extendable bar hangers with locking screws for variable width installation
- 'Reach and click' location system for securement of ArcSystem D1 Driver
- Center ring providing ceiling tile protection

MECHANICAL

- Frame manufactured from 18GA (0.0478") Cold-Rolled Steel
- PT114 Black powder coat finish
- Maximum load: 30lb (13.6KG)
- Maximum ceiling thickness: 0.75 inches (20mm)

COMPATIBILITY

- Designed for use with all recessable versions of the ArcSystem Pro One-Cell Fixture range

ORDERING INFORMATION

MODEL	DESCRIPTION
ARCP1RCB	ArcSystem Pro One-Cell Recessed Ceiling Bracket

INSTALLATION DIAGRAM

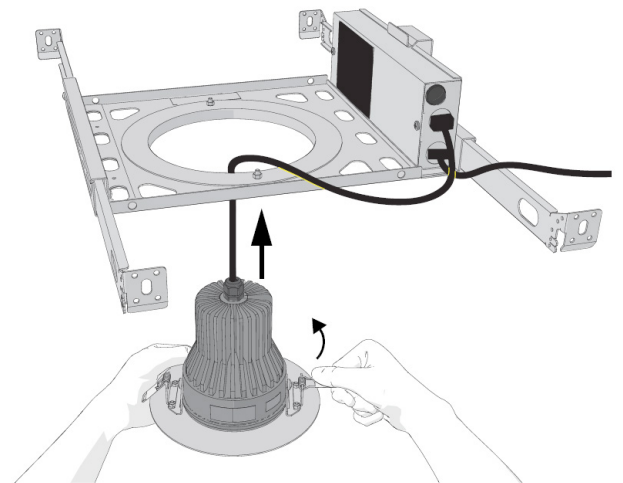

PHYSICAL

Product Dimensions

MODEL	LENGTH*		WIDTH		HEIGHT*	
	inches	mm	inches	mm	inches	mm
ARCP1RCB	24	610	15.29	388	4.35	110

*Length measurement with bar hangers fully extended (12" minimum to 24" maximum range)

*Excludes fixture

Product Weight*

MODEL	WEIGHT		SHIPPING WEIGHT	
	lbs	kgs	lbs	kgs
ARCP1RCB	3.6	1.63	5.0	2.27

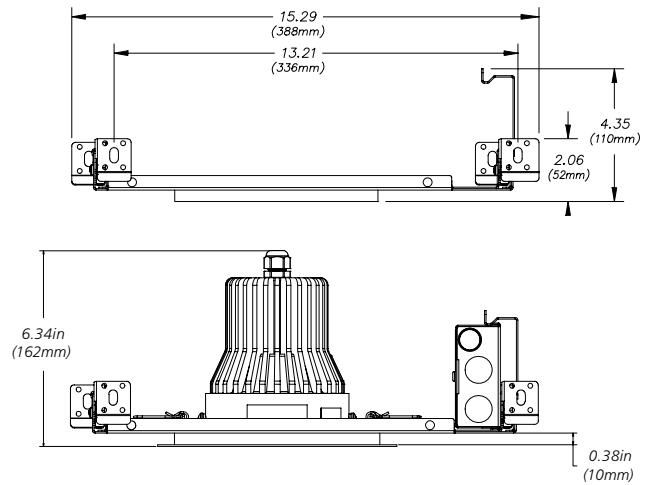
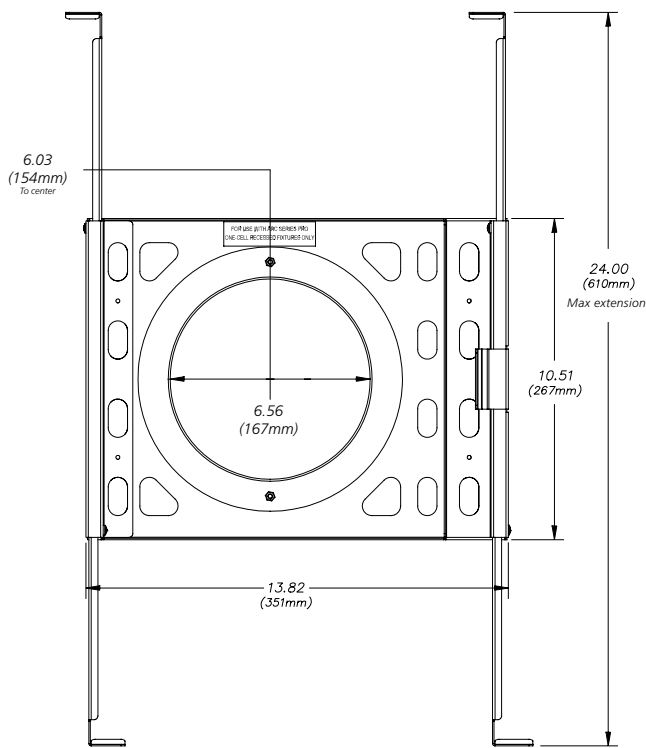

Corporate Headquarters • 3031 Pleasant View Rd, PO Box 620979, Middleton WI 53562 0979 USA • +1 608 831 4116
London, UK • Unit 26-28, Victoria Industrial Estate, Victoria Road, London W3 6UU, UK • +44 (0) 20 8896 1000
Rome, IT • Via Pieve Torina, 48, 00156 Rome, Italy • +39 (06) 32 111 683
Holzkirchen, DE • Ohmstrasse 3, 83607 Holzkirchen, Germany • +49 (80 24) 47 00-0
Hong Kong • Room 1801, 18/F, Tower 1 Phase 1, Enterprise Square, 9 Sheung Yuet Road, Kowloon Bay, Kowloon, Hong Kong • +852 2799 1220
Web • etconnect.com • Copyright©2017 ETC. All Rights Reserved. All product information and specifications subject to change. 7491L1002 Rev B 11/17