

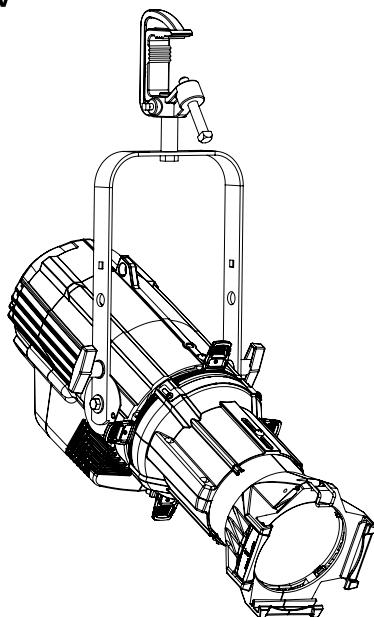

100V 115/120V 230/240V



## GENERAL INFORMATION

The **Source Four LED Studio HD** lighting fixture features the newest technology in high-output LEDs. This luminaire is ideal for video, film and other white-light applications. With its rugged die-cast enclosure and easy-to-operate user interface, the Source Four LED Studio HD is a powerful tool for any lighting professional. The fixture can be configured to operate under console control for studio systems or in stand-alone, no-controller-required settings for location lighting.

### Source Four LED Studio HD

The Source Four LED Studio HD fixture combines high output with carefully selected LED colors from the Selador x7 Color System™ to create a beautiful white light with amazingly rich depth. Easily adjust color temperature from 2700K-6500K.

All Source Four LED light engines work with all Source Four® lens tubes to deliver a high-quality, controllable beam of LED light. For the best results it is highly recommended that EDLT versions are used. We also offer a special LED-only version of the 50° lens tube.

## ORDERING INFORMATION

### Source Four LED Studio HD Light Engine with Shutter Barrel

(For use with fixed-field lens tubes only)

MODEL	DESCRIPTION
S4LEDSS	Source Four LED Studio HD with shutter barrel, black

### Source Four LED Studio HD Light Engine Body

(For use with zoom lens tubes and retrofits of existing fixtures)

MODEL	DESCRIPTION
S4LEDS	Source Four LED Studio HD – body only, black

Color options: -1 = White, -5 = Silver Gray/Custom Colors  
 Fixture ships with a soft-focus diffuser in the gobo holder and a five-foot PowerCon power input cable with connector of choice. See page 2 for connector options.

**Please note: Lens tubes to be ordered separately.**

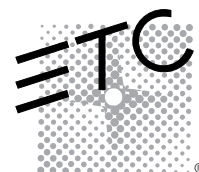

## SPECIFICATIONS

## GENERAL

- 60-LED array
- ETL listed to UL1573 – the standard for stage and studio lighting units
- IP20-rated for indoor use
- Power and DMX in/thru connections for easy setup
- User-friendly control interface with multiple modes and fixture settings

## PHYSICAL

- Rugged die-cast, all-metal housing
- Available in black (standard), white or silver (optional) or custom colors (contact factory)
- C-clamp
- Positive locking Double-clutch fixture body
- Slot for glass or stainless steel patterns and Soft Focus Diffuser
- Wide accessory slot with sliding cover for motorized pattern devices or optional iris
- Hanging yoke standard. Optional yoke/floor stand available

## ELECTRICAL

- 100VAC to 240VAC 50/60 Hz universal power input
- Neutrik power in and thru connections
- Up to nine fixtures (15A max) may be linked via power thru connector (10 fixtures total per circuit) when used with R20 Relay Module or Unison Echo Relay Panel. Consult breaker trip curves when used with other equipment
- Requires power from a non-dim source
- Inrush
  - 120V: 11A (First half-cycle)
  - 240V: 15A (First half-cycle)

## LED\*

- 50,000-hour LED life (50,000 hours to 70% intensity)
- 60 2.5W LED emitters

\*See additional LED notes on page three

## COLOR

- Provides rich variable-white light
- Color temperature range from 2700K to 6500K
- Broad-spectrum color interacts seamlessly with conventional sources
- Exclusive red-shift option emulates incandescent dimming performance
- Beautifully illuminates skin tones and other objects for natural appearance and high color rendering
- Also available with Lustr+, Daylight, or Tungsten LED arrays

## OPTICAL

- Use the included soft-focus diffuser for creating washes or soft light
- Best performance using ETC's EDLT lens tubes
- Can use all ETC Source Four interchangeable lens barrels: 5°, 10°, 14°, 19°, 26°, 36°, 50°, 70°, and 90° field angles as well as 19°, 26°, 36°, and 50° EDLT lenses
- For better performance, use the new LED 50° barrel

## CONTROL

- DMX512 in and thru via five-pin XLR connectors
- Multiple control options including RGB, strobe, and console-free Master/Slave mode
- See DMX Control Table for additional information
- 15-bit virtual dimming engine provides smooth, high-quality theatrical fades and minimizes color shift during dimming
- RDM functionality for address and setting changes

## SPECIFICATIONS

## THERMAL

- Ambient operating temperature of -4° to 104°F (-20° to 40°C)
- Active electronic thermal management for droop-free operation
- Quiet fan cooling
- Fixture is designed for continuous operation up to 104°F (40°C) ambient temperature and requires free flow of air around fixture housing

## ADDITIONAL ORDERING INFORMATION

## Power Input Cables

Use information below to order 5' power input leads with factory-fitted connectors

MODEL	DESCRIPTION
DPA-A	5' PowerCon™ to parallel blade U-ground (Edison) connector
DPA-B	5' PowerCon to 20A two-pin and ground (stage-pin) connector
DPA-C	5' PowerCon to grounded 20A twistlock connector
DPA-X	5' PowerCon to bare-end power input lead

## Power Thru Jumpers

Note: Power thru jumpers connect to fixture's output (thru) connector to provide link to successive fixtures

MODEL	DESCRIPTION
DPJ-5	5' PowerCon to PowerCon fixture to fixture jumper
DPJ-10	10' PowerCon to PowerCon fixture to fixture jumper

## Diffusers

MODEL	DESCRIPTION
S4LED-SFD	Source Four LED—Soft Focus Diffuser (included)
S4LED-SFDI	Source Four LED—Soft Focus Diffuser Permanent Installation Kit
S4LED-SWD6	Source Four LED—Smooth Wash Diffuser for 6.25" gel frame slots
S4LED-SWD7	Source Four LED—Smooth Wash Diffuser for 7.5" gel frame slots
S4LED-SWD12	Source Four LED—Smooth Wash Diffuser for 10° lens tubes
S4LED-SWD14	Source Four LED—Smooth Wash Diffuser for 5° lens tubes

The Soft Focus Diffuser fits into a standard A-Size pattern holder and delivers beautiful homogenized light when not in sharp focus. Also, use with patterns for dappled and soft-edge projections.

The Smooth Wash Diffuser is used when extra-smooth blending of multiple Source Four LED fixtures is required. The smooth wash diffuser is placed into the gel frame slot of the lens tube.

## PREFERRED LENSING OPTIONS

(Lenses sold separately)

## Fixed-Beam Lenses

MODEL	DESCRIPTION
LED50LT	LED specific 50° EDLT with lenses installed
LED50LT-1	LED specific 50° EDLT (white) with lenses installed
436EDLT	36° EDLT with lens installed
436EDLT-1	36° EDLT (white) with lens installed
426EDLT	26° EDLT with lens installed
426EDLT-1	26° EDLT (white) with lens installed
419EDLT	19° EDLT with lens installed
419EDLT-1	19° EDLT (white) with lens installed
490LT	90° with lens installed
490LT-1	90° (white) with lens installed
470LT	70° with lens installed
470LT-1	70° (white) with lens installed
414LT	14° with lens installed
414LT-1	14° (white) with lens installed
410LT	10° with lens installed
410LT-1	10° (white) with lens installed
405LT	5° with lens installed
405LT-1	5° (white) with lens installed

## Zoom Lens Assemblies

Use with light engine body models.

MODEL	DESCRIPTION
41530LT	Source Four 15-30° Zoom lens assembly
42550LT	Source Four 25-50° Zoom lens assembly

## Power Consumption at Full Capacity

MODEL	VOLTAGE (V)	CURRENT (A)	MAX POWER (W)
Source Four LED Studio HD	120	1.07	127.1

## ADDITIONAL ORDERING INFORMATION

## Fixture Accessories

MODEL	DESCRIPTION
400CC	C-Clamp (included)
400SC	Safety Cable
400PH-A	Pattern holder (A size)
400PH-B	Pattern holder (B size)
400PH-G	Glass pattern holder
400RS	Drop-In Iris
400CF	Colorframe (6.25")
407CF	7.5" square color frame
400DN	Donut
400TH	Top Hat
400HH	Half Hat
DPSJ-X	25' PowerCon to Edison input power cable with inline switch

## NOTES ABOUT LED LUMINAIRES

All LED sources experience some lessening of light output and some color shift over time. LED output will vary with thermal conditions. Based on the LED manufacturer's B50 L70 specification, a Selador luminaire will achieve ~70% of its initial output after 50,000 hours of typical usage. In individual situations, LEDs will be used for different durations and at different levels. This can eventually lead to minor alterations in color performance, necessitating slight adjustment to presets, cues or programs.

## CRI AND CQS RATINGS

Source Four LED fixtures were evaluated for CRI and CQS performance using measured output spectrum and optimized mix solutions for the best spectral match to black body sources at 3200K and 5600K.

FIXTURE	CRI	CQS	Color Fidelity	Duv
S4 LED Studio HD Reg at 3200K	94	95	93	0.000
S4 LED Studio HD Reg at 5600K	91	87	86	0.000

All Source Four LED luminaire versions provide excellent color rendering to the eye, particularly at higher color temperature settings such as 5600K. In most cases, the Duv is 0.000. A Duv rating of 0.000 indicates that the color mix used is exactly on the black body line, with no green or magenta tint.

CONTROL OPTIONS

User settings on Source Four LED Studio HD fixtures allow multiple operational modes and settings for either console operation via DMX protocol or stand-alone operation. The expanded LCD display provides easy navigation to all possible settings and options. Some of the setting options are:

- Multiple DMX choices for multiple operational modes
- Multiple dimming curve options
- Preset color temperatures and sequences for stand-alone (no-console-required) operation
- White-point selection – i.e. 3200K, 5600K, etc.
- Loss of data behavior options – instant off, hold last look for two minutes, etc.
- Output modes – three output options that offer the user a choice between maximum output and maximum consistency

See the user manual for a complete explanation of all of the control settings and options for the Source Four LED.

Quick Setups

To assist in managing the numerous control and fixture behavior choices, five combinations of operational settings are available to quickly get started. These settings are specifically created for different applications and are easily accessible at the fixture display. Each setting can then be modified as required to take advantage of all of the possible control features.

Setting Title	Profile	Description	Typical Features*
General	Direct	Factory Default: For general-purpose use, including interior architectural applications	<ul style="list-style-type: none"> <li>• Standard dimming curve</li> <li>• Regulated output for color consistency</li> </ul>
Stage	HSI Plus 7 Enabled	Theatrical lighting: Duplicates the color and dimming behavior of tungsten stage lighting fixtures	<ul style="list-style-type: none"> <li>• Incandescent dimming curve</li> <li>• Regulated output for color consistency</li> <li>• 3200K white-point setting</li> </ul>
XT Arch	HSI	Exterior architectural lighting: Provides a high degree of color consistency in high ambient temperature environments	<ul style="list-style-type: none"> <li>• Standard dimming curve</li> <li>• Protected output</li> <li>• 3200 white-point setting</li> </ul>
High Impact	RGB	Event lighting: Enables quickest response, simple RGB control and strobe channel for maximum effect usage	<ul style="list-style-type: none"> <li>• Quick dimming curve</li> <li>• Boost mode for maximum intensity</li> <li>• 5600K white-point setting</li> </ul>
Studio	Studio	Studio Factory Default: Enables three-parameter control of white light (intensity, white point, and tint) via DMX from console or from fixture display – no console required	<ul style="list-style-type: none"> <li>• Linear dimming curve</li> <li>• Regulated output mode for color consistency</li> </ul>

\*See user manual for complete list of features for each Quick Setup

CONTROL OPTIONS

DMX Input Channel Profiles

DMX Profile	DMX Channels	Channel Assignments	Notes
Studio	6 (Ch. 4 not used)	1 – Intensity 2 – Color Point (CCT) 3 – Tint 4 – n/a 5 – Strobe 6 – Fan Control	Controls fixture as a white-light unit. If no DMX, i.e. console input, is present, fixture can be adjusted for these three parameters on the UI at the back of the unit.
Direct	10	1 – Red 2 – RedOrange 3 – Mint 4 – Blue 5 – Indigo 6 – N/A 7 – N/A 8 – Intensity 9 – Strobe 10 – Fan Control	Direct control of each individual color with a separate master intensity channel. Color calibration of LEDs is not active in this mode. This profile will produce additive color cross-fades.
HSI	6	1 – Hue (coarse) 2 – Hue (fine) 3 – Saturation 4 – Intensity 5 – Strobe 6 – Fan Control	High-resolution hue (two channels), saturation, and intensity control. HSI mode will produce color crossfades around the color space.
HSIC	7	1 – Hue (coarse) 2 – Hue (fine) 3 – Saturation 4 – Intensity 5 – Strobe 6 – Fan Control 7 – Color Point (CCT)	High-resolution hue, saturation and intensity control as above, with the addition of a color-point channel to adjust the color temperature of the fixture in both white light and color. Color crossfade performance is the same as HSI.
RGB	6 (Ch. 4 not used)	1 – Red 2 – Green 3 – Blue 4 – n/a 5 – Strobe 6 – Fan Control	Effectively addresses all seven colors via three channels of control. RGB profile will produce additive color crossfades.

Additional profile options

Plus 7	Seven additional color control channels are available in RGB, HSI, and HSIC input profile settings. For example, HSI with 'Plus 7' enabled becomes a 15-channel profile:	<ul style="list-style-type: none"> <li>1 – Hue (coarse)</li> <li>2 – Hue (fine)</li> <li>3 – Saturation</li> <li>4 – Intensity</li> <li>5 – Strobe</li> <li>6 – Fan Control</li> <li>7 – n/a</li> <li>8 – Plus7 Control on/off</li> <li>9 – Red</li> <li>10 – RedOrange</li> <li>11 – Mint</li> <li>12 – Blue</li> <li>13 – Indigo</li> </ul>	<p>The desired color and intensity is achieved by using the HSI or RGB channels</p> <p>Placing channel seven at a value over 51% gives the fixture a 15-channel profile.</p> <p>Channels 9-15 represent the native colors of the fixture and allow the operator to adjust individual color channels to fine-tune the color output.</p>
Strobe	Variable strobe control: 0% is no strobe. The fixture output will strobe more rapidly as the strobe channel value approaches 100%.		

PHYSICAL

Source Four LED Weights and Dimensions

	WEIGHT*		SHIPPING WEIGHT	
	lbs.	kgs	lbs	kgs
With Barrel	18.3	8.3	28	12.7
Without Barrel	14.3	6.5	23	10.4

\* Does not include mounting hardware or lens tube

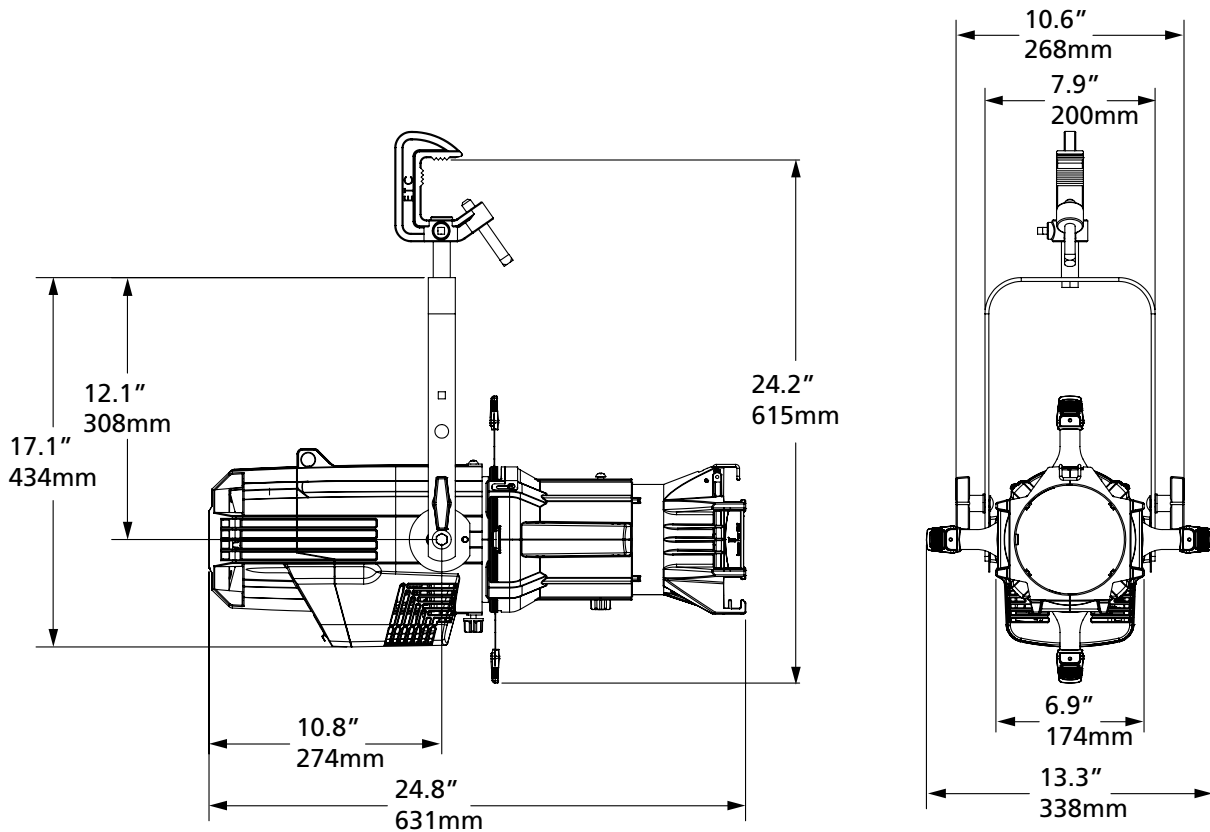

**Corporate Headquarters** • 3031 Pleasant View Rd, PO Box 620979, Middleton WI 53562 0979 USA • Tel +1 608 831 4116 • Fax +1 608 836 1736

**London, UK** • Unit 26-28, Victoria Industrial Estate, Victoria Road, London W3 6UU, UK • Tel +44 (0)20 8896 1000 • Fax +44 (0)20 8896 2000

**Rome, IT** • Via Pieve Torina, 48, 00156 Rome, Italy • Tel +39 (06) 32 111 683 • Fax +44 (0)20 8752 8486

**Holzkirchen, DE** • Ohmstrasse 3, 83607 Holzkirchen, Germany • Tel +49 (80 24) 47 00-0 • Fax +49 (80 24) 47 00-3 00

**Hong Kong** • Room 1801, 18/F, Tower 1 Phase 1, Enterprise Square, 9 Sheung Yuet Road, Kowloon Bay, Kowloon, Hong Kong • Tel +852 2799 1220 • Fax +852 2799 9325

**Web** • www.etcconnect.com • Copyright©2014 ETC. All Rights Reserved. All product information and specifications subject to change. 7460L1005 Rev. D USA 06/14

U.S. and international patents pending.