

115/120V

Smart Solutions™ Series

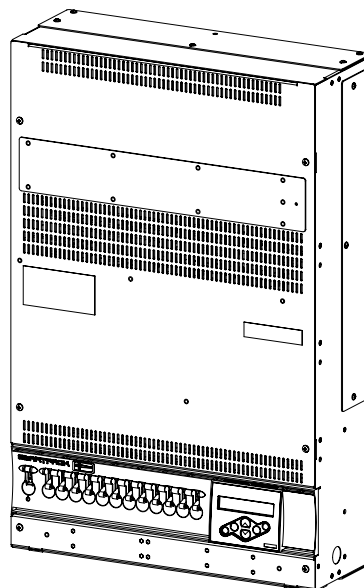
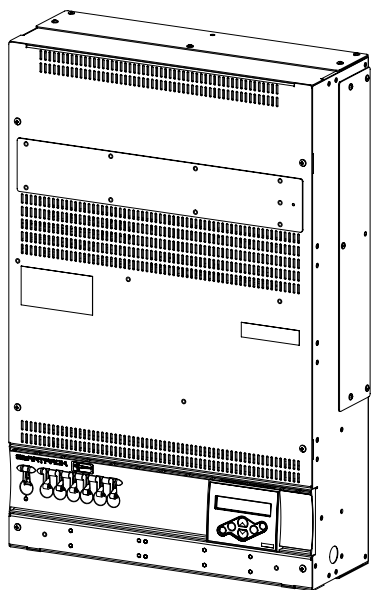

GENERAL INFORMATION

The extreme functionality of the SmartPack built into a compact affordable wall-mount unit. This small wall-mount pack provides easy, reliable dimming operation. The ThruPower model also offers free choice of dimmed, relay, or hot power at each branch circuit. SmartPack Wall Mount comes standard with remote preset and sequence control from up to four SmartLink stations.

APPLICATIONS

- Ballrooms
- Restaurants
- Houses of worship
- Multi-purpose rooms
- Small corporate meeting rooms
- Small performance spaces

FEATURES

- Six or 12 dimmer units available
- Capable of dimming multiple load types: incandescent, low voltage, two-wire fluorescents
- Versatile control via DMX-512 and/or SmartLink
- DMX addressing and softpatch via keypad
- Built-in presets (32) and sequencer with programmable fade and hold times allow stand-alone operation
- SmartLink provides synchronization of presets and sequences across multiple packs
- Optional LinkPower Supply powers four stations
- Auto-Restart returns to previous state after power cycled
- Control-power switch puts unit in standby mode
- Multi-language: English, Spanish, German and French
- Fully rated magnetic circuit breakers
- Bypass contact input instantly switches on selected loads, while switching others off
- ThruPower model offers air gap relays for switching of electronic loads.
- Full compliance with UL, cUL, FCC and CE regulations

ORDERING INFORMATION

SmartPack Wall Mount

| MODEL | DESCRIPTION |
|-------------|---|
| SL620W | 6 x 20A SmartPack Wall Mount |
| SL620W-LPS | 6 x 20A SmartPack Wall Mount with LinkPower Supply |
| SL1210W | 12 x 10A SmartPack Wall Mount |
| SL1210W-LPS | 12 x 10A SmartPack Wall Mount with LinkPower Supply |
| SL1210TPW | 12 x 10A SmartPack Wall Mount with ThruPower |

SmartPack Wall Mount Accessories

| MODEL | DESCRIPTION |
|----------|------------------------|
| SMPK-RRM | Rack Mount Kit (rails) |

SmartLink Accessories

| MODEL | DESCRIPTION |
|---------|----------------------------------|
| S-LPS | LinkPower Supply Kit |
| S-10005 | SmartLink 5-Button Station* |
| S-10010 | SmartLink 10-Button Station* |
| S-ATC | SmartLink Astronomical TimeClock |

*Stations require one LinkPower Supply per system. Only one LinkPower Supply allowed per system. Four stations supported.

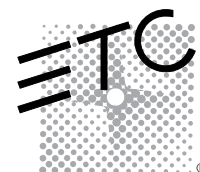

SPECIFICATIONS

GENERAL

- Approvals and certifications:
 - Underwriters Laboratories tested and Listed to the following standards:
 - UL508 (File: E152039)
 - Complies with ESTA DMX512A Standards

ELECTRICAL

- Maximum feed capacity:
 - 3 x 40A, Three Phase, four-wire & ground
 - 2 x 60A, Single Phase, three-wire & ground
- Easily switches from single phase to three phase
- Input voltage range from 85 – 140VAC, 47 – 63 Hz
- Input lugs rated for up to 2AWG
- Standard output connection via DIN Rail spring terminals, rated for up to 8AWG
- Fully rated magnetic circuit breakers to eliminate nuisance tripping
- High-quality 200µs toroidal filters
- Modular SCR and bonded heat sink assembly with superior surge, thermal transfer, and short-circuit immunity
- 2500V isolation between control and power components

CONTROL WIRING

- Removable terminals for DMX512, SmartLink and Contact Input rated for maximum of 12AWG wire

MECHANICAL

- 16-gauge steel construction
- Fine-textured, scratch-resistant paint
- Removable knockout panels with pass-through plenum for side-by-side or top-to-bottom mounting configurations (sides, top and bottom)
- Full front access (side clearance not required)
- Optional rack-mount kit (requires 15U spacing)
- Recessed control connectors and protected circuit breakers
- Air gap relay ratings (in ThruPower model)
 - 5 million mechanical activations
 - 200,000 full load activations

THERMAL

- Ambient temperature between 32°F (0°C) and 95°F (35°C)
- Humidity between 30 – 95% (non-condensing)
- Fan-forced airflow from bottom to top
- Low-noise, temperature-controlled fan
- Efficiency = 96% or better, maximum dissipation 3% of connected load (Max. 3,100 BTUs)

USER INTERFACE

- High-contrast 20-character by two-line backlit LCD
- Six-button blue phosphorescent keypad
- Power status indicator LED (Blue)
- DMX status indicator LED (Green)
- Power Mode selection switches per branch circuit

PHYSICAL

SmartPack Wall Mount Dimensions

| MODEL | HEIGHT | | WIDTH | | DEPTH | |
|------------|--------|-----|--------|-----|--------|-----|
| | inches | mm | inches | mm | inches | mm |
| SL620W | 26.24 | 666 | 17.14 | 435 | 6.2 | 157 |
| SL1210W | 26.24 | 666 | 17.14 | 435 | 6.2 | 157 |
| SL1210TPW* | 30.24 | 768 | 17.14 | 435 | 6.2 | 157 |

*Note: ThruPower Model height increases by 4"

SmartPack Wall Mount Weight

| MODEL | WEIGHT | |
|---------|--------|-------|
| | lbs | kgs |
| SL620W | 46.2 | 20.96 |
| SL1210W | 48.0 | 21.77 |

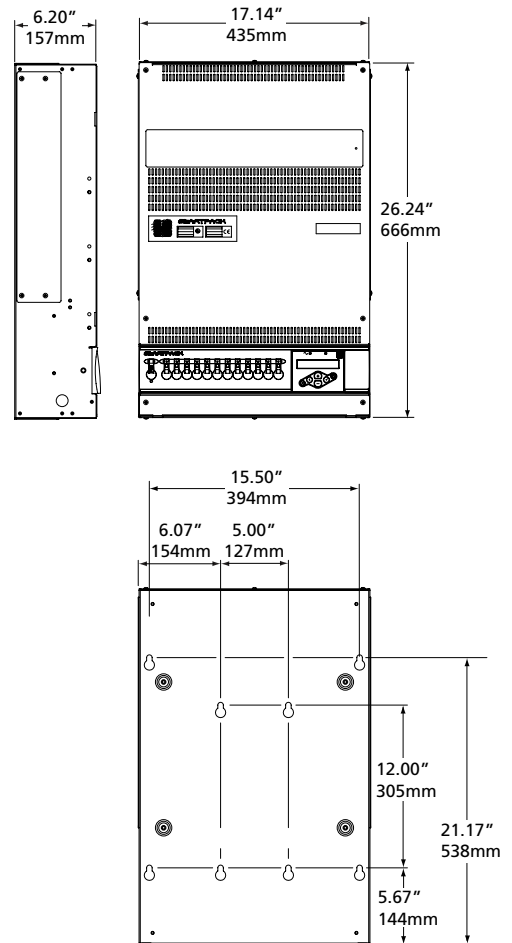

Corporate Headquarters • 3031 Pleasant View Rd, PO Box 620979, Middleton WI 53562 0979 USA • Tel +1 608 831 4116 • Fax +1 608 836 1736
London, UK • Unit 26-28, Victoria Industrial Estate, Victoria Road, London W3 6UU, UK • Tel +44 (0)20 8896 1000 • Fax +44 (0)20 8896 2000
Rome, IT • Via Ennio Quirino Visconti, 11, 00193 Rome, Italy • Tel +39 (06) 32 111 683 • Fax +44 (0) 20 8752 8486
Holzkirchen, DE • Ohmstrasse 3, 83607 Holzkirchen, Germany • Tel +49 (80 24) 47 00-0 • Fax +49 (80 24) 47 00-3 00
Hong Kong • Room 1801, 18/F, Tower 1 Phase 1, Enterprise Square, 9 Sheung Yuet Road, Kowloon Bay, Kowloon, Hong Kong • Tel +852 2799 1220 • Fax +852 2799 9325
Web • www.etcconnect.com • Copyright©2013 ETC. All Rights Reserved. All product information and specifications subject to change. 7021L1000 Rev. E Printed in USA 11/13

SmartLink® products protected by US and International patents pending